



AquaMetrix AM-2300 Multi-Input Controller



Installation and Operation Manual

Table of Contents

Overview	3
1.1. Introduction	3
1.2. Specifications	3
2. Installation	4
2.1. Panel Mounting	4
2.2. Power, Probe, and Network Cabling	5
2.3. Relay Wiring	8
2.4. Powering Up the 2300	8
2.5. Configuring the 2300 for Network Operation	8
3. Operating the 2300 from the Front Panel	9
3.1. Front Panel Display	9
3.2. Front Panel Menu	11
3.3. Calibrating Sensors from the Front Panel	13
3.4. Setting Relays from the Front Panel	15
3.5. Saving and Restoring Your Configuration from the Front Panel	16
4. Operating the 2300 from a Web Interface	16
4.1. Setting up an Ethernet Connection to a Network Router	16
4.2. Connecting to a 2300 within Your Local Area Network (LAN)	17
4.2.1. Assigning an IP address via DHCP	17
4.2.2. Assigning a Fixed IP Address	17
4.2.3. Accessing the 2300 from a Wide Area Network	18
4.3. Setting up a Direct Ethernet Connection	19
4.3.1. Settings for MacOS.....	19
4.3.2. Settings for Windows.....	20
4.3.3. Settings for the 2300.....	22
4.3.4. Log In!.....	22
4.4. Accessing the 2300 from a Private Wireless Network	22
5. Configuring the 2300 via the Web Interface	23
5.1. Probe Status	24
5.2. Remote Display	26
5.3. Logs	26
5.3.1. Data Logs.....	26
5.3.2. Daily Logs	26
5.3.3. Alarm Logs.....	27
5.3.4. System Logs.....	27
5.4. Setup	27
5.5. User Maintenance	29
5.5.1. Data Logging Configuration.....	30
5.6. Network Setup	31
5.6.1. Ethernet Configuration	31
5.6.2. Web Server Configuration.....	31
5.6.3. Modbus/TCP Server Setup	32
5.6.4. Email Setup	32
5.7. System Configuration	38

5.7.1.	Name & Time Configuration	38
5.7.2.	LCD Configuration	38
5.7.3.	Unit Configuration.....	39
5.8.	System Documentation	39
5.9.	Advanced.....	39
5.9.1.	Modbus Address List.....	39
5.9.2.	List Logged In Users.....	39
5.9.3.	Prepare for Shutdown.....	39
5.9.4.	Restart System	39
5.9.5.	Restore to Factory Defaults	39
6.	Configuring Probes	39
6.1.	Overview of Probe Types.....	39
6.2.	Adding an Analog Sensor	40
6.2.1.	Probe Selection	41
6.2.2.	Probe Information.....	41
6.2.3.	Scaling	42
6.2.4.	Linear Scaling/Calibration	42
6.2.5.	Example: Calibrating a pH probe	43
6.2.6.	Scaling of a Transmitter signal	44
6.2.7.	Non-Linear Scaling	44
6.2.8.	Scale Factors	45
6.2.9.	Probe Details.....	45
6.2.10.	Probe Description	46
6.2.11.	First Action Configuration	47
6.2.12.	Action Name.....	48
6.2.13.	Action Type	48
6.2.14.	Acknowledging Alarms.....	49
6.2.15.	Selecting a Relay	50
6.2.16.	Emailing Alarms and Controls	51
6.2.17.	Adding Additional Actions.....	51
6.3.	Connecting a Pulse Output (Flow) Sensor	51
6.3.1.	Probe Selection	51
6.3.2.	Probe Information.....	52
6.3.3.	K-Factor Scaling/Calibration.....	52
6.3.4.	Probe Details.....	53
6.3.5.	Probe Description	53
6.3.6.	Action Configuration	54
6.4.	Connecting Virtual Probes	54
6.4.1.	Configuring a Totalizer Probe.....	54
6.4.2.	Configuring Differential Sensors	57
6.4.3.	Configuring Virtual sensor using Formula.....	58
7.	Appendix.....	58
7.1.	Optional I/O Card Types	58
7.1.1.	4-channel Analog Input Card	58
7.1.2.	3-channel Digital Input + 4-channel Digital Relay Output card.....	58
7.1.3.	6-channel Relay Output card	58
7.1.4.	7-channel Digital Input card.....	59

7.1.5.	4-channel Analog Output card	59
7.2.	Email Keyword List	61
7.3.	Panel Mounting.....	63
8.	Get the Latest Firmware	63

Overview

1.1. Introduction

The AquaMetrix 2300 Controller is the first multi-input controller that brings web-based operation down to a price that can be afforded by just about any facility. Its combination of features—remote control, data logging, email alerts and seven inputs—are unparalleled in the water monitoring market. Its Setup Wizards make set-up and operation a snap.

This manual attempts to cover the many facets of setup and operation in detail.

The standard configuration accepts inputs for four 4-20mA (analog) sensors and three frequency output (aka digital or pulse) sensors—mainly flow sensors such as paddlewheels and magmeters. Outputs include four relays and virtually unlimited email/text notifications. The 2300 Controller provides remote viewing capability and configuring with password from any connected web browser. It also provides data logging with downloading or emailing of log files in CSV format. There is also one available slot for an optional card, which can expand digital inputs or relays outputs, or add analog outputs.

We are constantly making improvements to the user interface so please check in to make sure you have the latest version.

1.2. Specifications

	Inputs
Analog	Four 4-20 mA powered or unpowered current loops *Expandable to 8 with an additional card
Pulse Rate	Three isolated inputs suitable for flow sensors, up to 24 VDC
	Outputs
Relays	Four 120V/240 V @ 10A/5A expandable with additional card.*
Alerts	Emails and/or texts for alarms, relay actions, errors, or reminders
Web	Remote viewing with a browser on a computer, tablet, or smart phone. Remote programming from any of these.
Data logging	Logging of CSV files directly to internal microSD card
Digital Outputs	Modbus TCP over Ethernet connection.
Analog	Optional: Four non-isolated 4-20 mA outputs proportional to any

Outputs	reading.*
	Control
Web or LAN	Viewing with a browser on a computer, tablet, or smart phone. Setup and control from any of these. Multi-user password protected.
Front Panel	Status, Probe enable/disable/calibrate, System Configuration
	Ratings
Power Input	0.2 A @ 115 VAC or 15 W
Temperature	0 to 70°C
Protection	NEMA 4X, 1/4 DIN panel mount or wall mount with optional hardware
	Physical
Mounting	1/4 DIN panel mount or wall mount with optional hardware
Dimensions	Front cover: 6.5" wide x 5.5" tall; rear enclosure: 3.5" wide x 3.5" tall x 4.5" deep
Power	120 or 220 VAC, 60 or 50 Hz, auto-recognized. (Cable not included) 24 VDC also available
Weight	2 lbs.

****One expansion card slot is available***

2. Installation

WARNING: If this equipment is used in a manner not specified by the manufacturer as per the Users Manual, the protection provided by the equipment may be impaired.

2.1. Panel Mounting

Mount the 2300 Controller through the front panel, with the gasket on the outside of the mounting panel. Hook the sliding mounting blocks on each side of the back of the 2300 Controller enclosure and tighten the set-screws against the mounting panel with a torque of 4 in-lb, as shown in Figure 2-1.

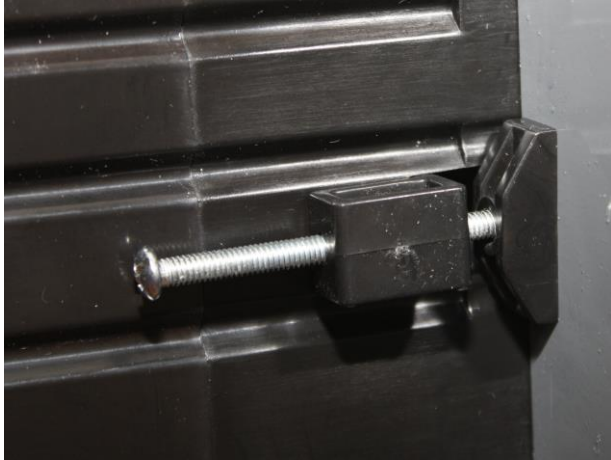

Figure 2-1 - Mounting hardware attached to panel with 4 in-lb of torque

2.2. Power, Probe, and Network Cabling

A picture of the rear of the 2300 is shown below in Figure 2-2. We recommend removing the Molex connectors and connecting wires to them and then attaching the connectors to the unit.

Connect the:

- Power cord
- CAT-5 Ethernet cable—to be used later as described in Section 5.
- Probe wires: Two-wire 4-20 mA cables connect to the analog connector. Pulse inputs connect to the digital inputs.

Probe wiring depends on the type and manufacturer of the probe, and instructions can be found with each probe. We show examples of the different wiring diagrams in Figure 2-3 that may be called for by your analog (4-20 mA) probes, but please look up your individual probe directions. Connections for flow meters, which output a pulse frequency, such as paddle wheels or magmeters, use the pulse input connector (“dig in 1” et al).

Note: The 2300 controller comes with a microSD card that is used for firmware updates. **If you purchase a second card it is important that the card has a speed rating of at least 10.**

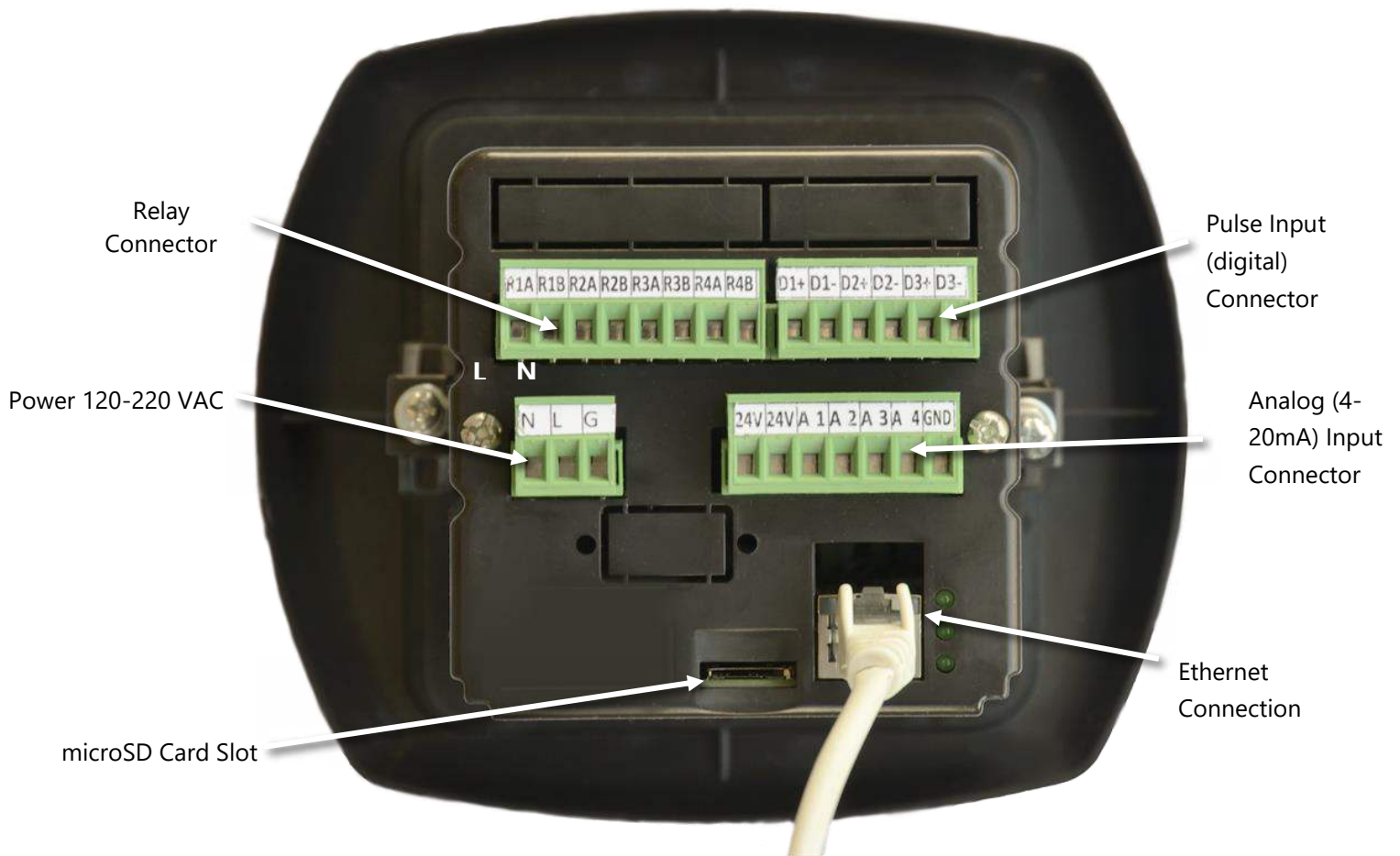

Figure 2-2 - 2300 Controller back panel

Figure 2-3 shows the wiring for the three most common analog sensors plus a current sinking flow meter. Please refer to the sensor manufacturer's instructions to be sure you wire your sensor correctly. This is especially important for 3-wire probes, which differ in the power connection of the 4-20 mA wiring.

Electrical Connections between the AquaMetric 2300 and Common Sensors

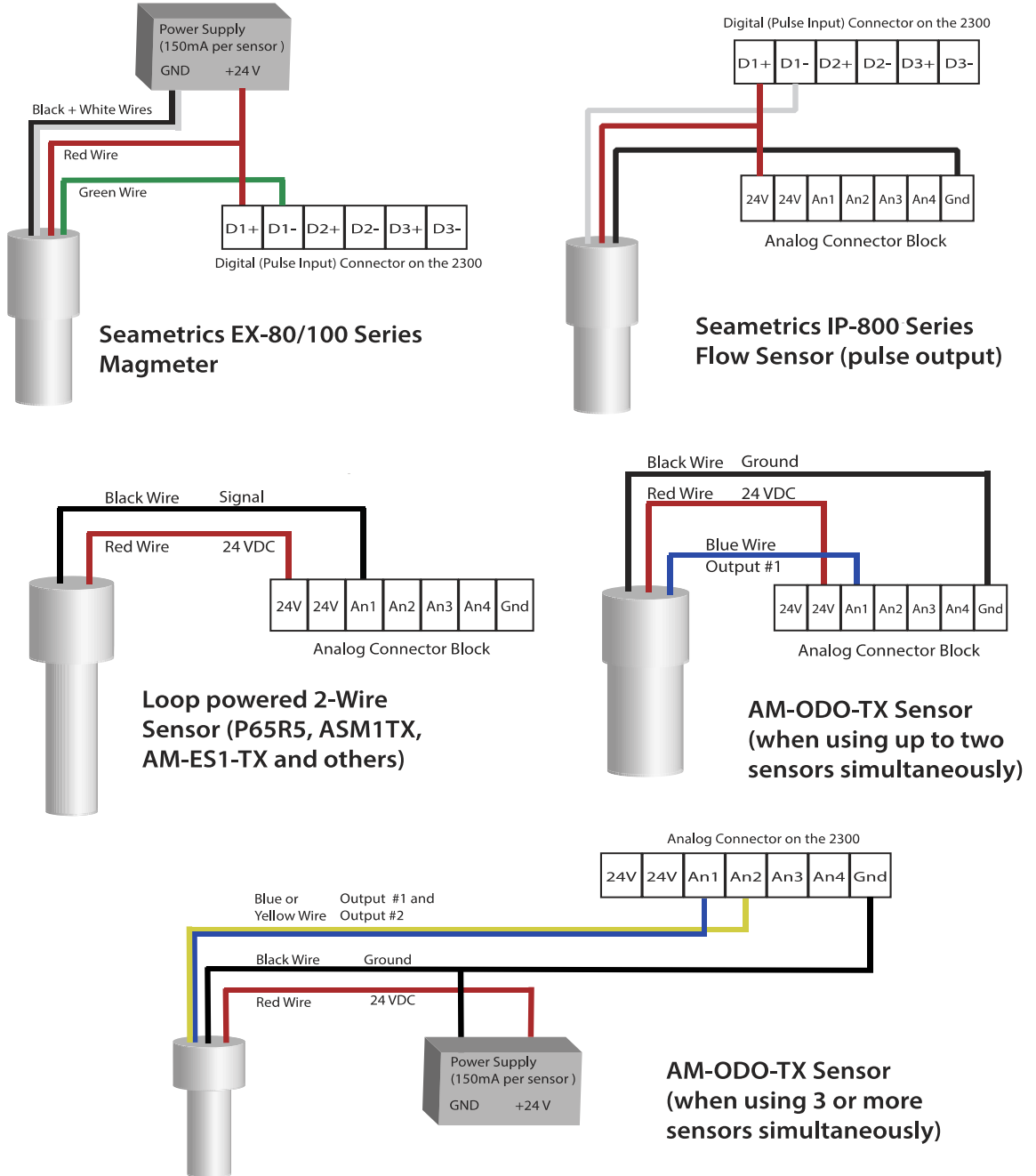

Figure 2-3 - Probe wiring diagrams. There are other possible three-wire probe setups, so please refer to your specific probe's instructions for proper hook up.

2.3. Relay Wiring

The 2300 controller has 4 relays that can be expanded to 10 with the addition of a second card. The relays are capable of handling 120 V @ 10 A or 240 V @ 5 A. They can also be part of a 24 VDC circuit. Unlike the Shark-120 the relays are not powered. To power a relay and the device to be controlled (e.g. a pump or a solenoid) wire the relay circuit as shown.

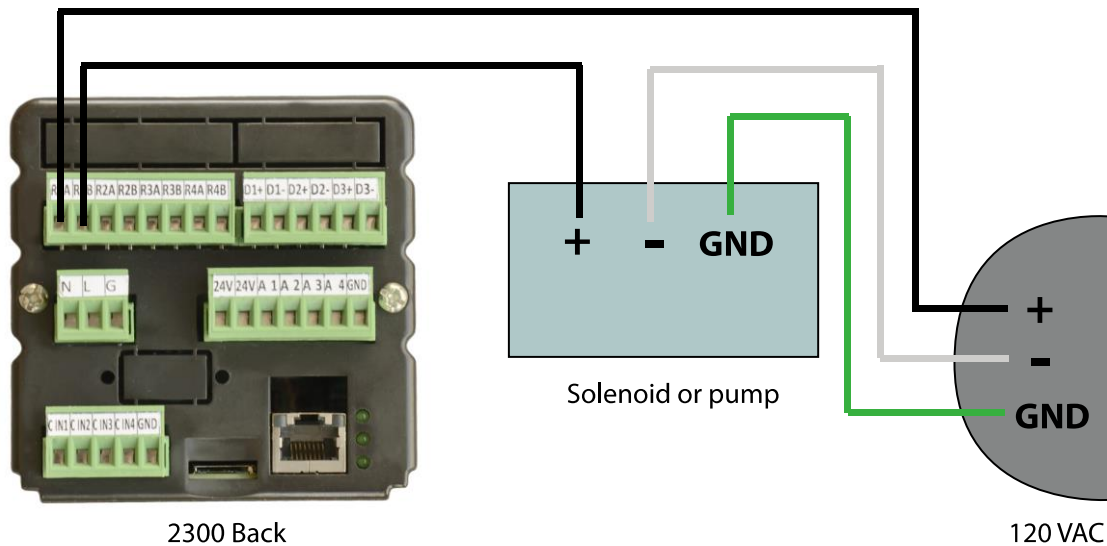

Figure 2-4 - Electrical Connections for a circuit involving a relay, power source and device.

2.4. Powering Up the 2300

With the probes connected, power up the 2300. If the controller is operating properly, the green LED's on the back panel indicate proper operation. (See Figure 2-2.) From top to bottom:

1. The top most LED is the **Fault** light it should be slowly blinking.
2. The middle LED is the **System Operating** light and it should be quickly blinking.
3. The bottom LED is the **Power On** light and it should be on and steady.

The **Run** screen should appear and display 4 panes. The new controller will have all four quadrants empty.

In order to add probes, you need to carry out set-up over a network using a web browser. See Section 4.1 or 4.3 of this guide for network setup, and Section 5 for configuring the AM-2300 over the network.

2.5. Configuring the 2300 for Network Operation

The default setup for the 2300 includes Dynamic Host Control Protocol (DHCP) for automatically assigning an IP address to a unit. This IP address is the key piece of information that allows users to locate and log into any 2300 on a local or wide area network.

Once the controller is connected a Local Area Network (LAN) the router will assign the 2300 its IP address. To find out what that IP is:

1. Click on the **Menu** button.
2. Click on the top-most menu item, **View System Info**.
3. The IP address is listed on the second line. See Figure 2-5.



Figure 2-5 - The IP address of the 2300 assigned by the router is listed on the second line.

Section 4.3 goes into network connectivity in greater depth.

3. Operating the 2300 from the Front Panel

3.1. Front Panel Display

The 2300 front panel display shows a series of RUN screens and MENU screens. It does not have the full functionality of the web interface and is meant to be a local display and secondary user interface.

There are eight navigation buttons below the screen: four arrow buttons and the following:

- The **RUN** button brings up the quad screen from anywhere
- The **MENU** button brings up the front panel menu
- The **BACK** button returns the user to the previous screen.

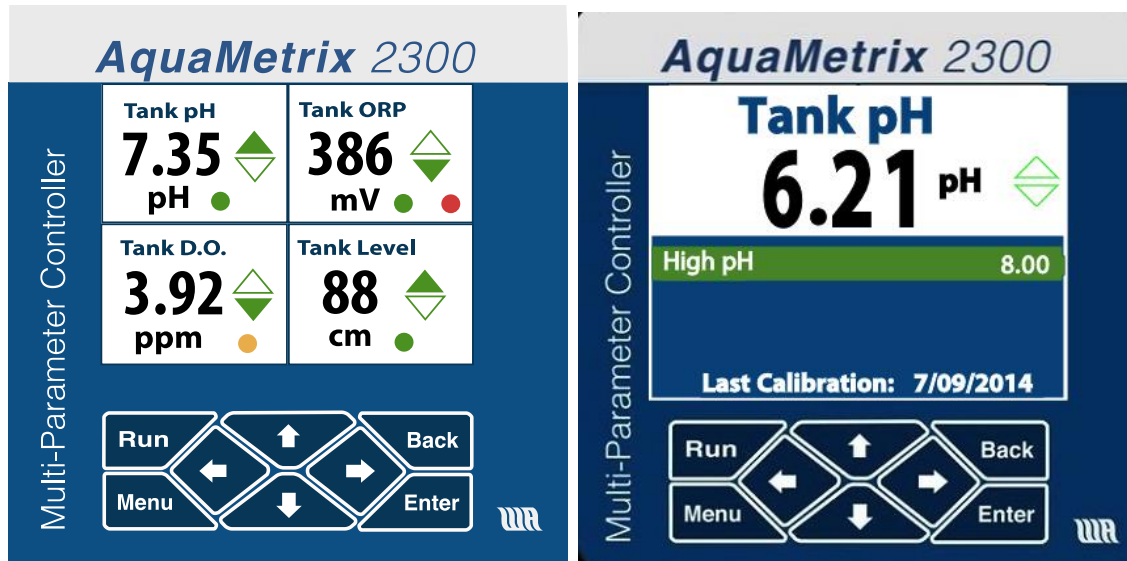

Figure 3-1 - The Run display on the left reports 4 process values at a time. If there are more than 4 pressing ↓ reveals the hidden values. The identical image appears on the web browser. The Detail screen on the right shows the detailed status of the Tank pH condition, including process value and alarm or relay.

- The **Run** screen includes a summary screen showing the status and values of 4 probes at one time. If more than 4 probes are enabled in the controller, the ↓ and ↑ buttons will allow you to see additional probes.
- Each quadrant in the **Run** screen shows a probe label, current value with units, trend arrows for the reading, and a status light for the controller outputs. The status light is:
 - Green for normal operation
 - Yellow for an activated relay
 - Red for an activated alarm
- Pressing → brings you to the **Detail** status screen for one sensor. As Figure 3-1 shows, this screen lists the action outputs for this probe, including the action description and set-point value, and the last calibration date. The actions are color coded, with green for normal operation, red for alarm condition, and yellow for an activated relay.
- The ↓ and ↑ buttons cycle through screens of individual probes. Pressing the ← button brings back the **Run** screen.
- When a probe activates an alarm the front panel display automatically switches to a flashing detailed Detail screen. To restore the display to the **Run** screen press the **Run** button.
- Pressing the **Enter** button will bring up a Meter Action screen, allowing the user to acknowledge an alarm, if active, or setting relay trip points.
- Press the **Run** button to return to the **Run** screen.



Figure 3-2 - The channel Detail screen and Configure screen for Channel 1

The Detail screen lists alarm and relay set points, last calibration date, and will flash when the channel is in alarm mode. The configure screen allows resetting of the alarm and relay set points, alarm acknowledgement, and zeroing of the totalizer and dispenser functions and other channel-specific functions.

3.2. Front Panel Menu

The front panel menu is limited to a select group of functions. The outline of this menu structure is listed in Table 1.

These front panel menu items ensure that the unit may be connected to the web interface to allow the complete configuration that you will need to do. When not connected to the web (or computer), the unit still operates and all non-web-based features are still fully functional.

Table 1 – Front panel menu options.

	Main Menu
View System Info	Unit name, IP address, software version, and system status information
Disable/Calibrate Probe	Manually disable, enable, or calibrate defined probes
Backup/Restore	Save or restore the unit configuration and setup to a removable SD card
Reboot System	Powers down and restarts controller
Prepare for Power Down	After a confirmation dialog is confirmed, all probes are disabled, all logs are closed, and the system is put in a state where it is safe to remove power from the controller.
	Advanced Menu
Calibrate Analog In	Should be used only by skilled technician

Network Setup	Change the network between Dynamic (DHCP) and Static IP
Network Type	DHCP or Static IP; allows manual entry of static IP data
Web Server Port	Allows entry of port number
Restore to Factory Defaults	Erases all setup and calibration data.

The front panel menu choices are limited as the 2300 is designed to be configured and operated over a network via a web browser. However, there are several key functions available to the user on the front panel. These include calibration and setting up the network. The main menu is shown in Figure 3-3.

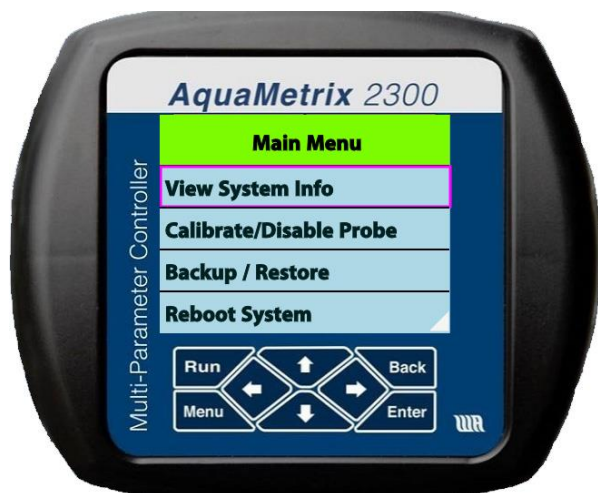

Figure 3-3 -Pressing the Menu button brings up the Main Menu screen.

Use the **↑** or **↓** keys to highlight an item, and press the **Enter** key to select it. If there are more than 4 choices available, the bottom (or top) corner on the right will show a white triangle or notch. Some front panel actions require a password to proceed. The default password is **48111**.

The menu options are listed in outline form below in Table 1. You may calibrate your probes from the front panel, but remember that full functionality of the unit is only available via the Ethernet cable from a network, or browser on a computer, tablet, or phone. Customize your unit via a network to display proper units, names of probes, and to configure alarms, relays, and notifications.

Table 2 – Front Panel Menu Structure

Menu Item	Description
View System Info	Single screen showing unit Name, IP Address, etc.
Calibrate/Disable Probe	Enable, disable, or calibrate probes
Select Probe	Any defined probe, including virtual probes
Select Action	Calibration is 2-point calibration for the analog inputs, K Factor scaling for the digital inputs.

Backup/Restore	Saves or Restores a configuration file onto/from the external micro-SD card, including probe setups and calibrations, alarm and relay set points, and system configuration.
Reboot System	Closes all open files and restarts system.
Prepare for System Shutdown	Closes all open files.
Advanced Menu	
Calibrate Analog In	Password protected for factory calibration only
View Precision Input	Not Used
Network Setup	Changes from DCHP to Static IP or vice versa, allowing settings for network type and web server port.

3.3. Calibrating Sensors from the Front Panel

Most routine operation of the AM-2300 is most conveniently done through the web interface. However, for some installations—especially industrial ones—calibration may be more conveniently done through the front panel. *Note that front panel calibration only allows 2-point calibrations.*

To calibrate from the front panel follow these instructions:

1. Press the **Menu** button.
2. Using the down arrow, select **Calibrate/Disable Probe** and click on **Enter**. A list of probes that have been configured will appear.
3. Using the down button, to select the probe you want to calibrate, and click on **Enter**.
4. A new menu appears with two choices. Using the down button, select **Perform Calibration** and click on **Enter**.
5. The next screen displays the existing calibration points for this probe, with the input current on the left and the value readout to its right. Each point can be modified or left alone.



Figure 3-4 – Select Probe Calibration and then select 1 or 2 points at which to calibrate.

6. You may either enter calibration points—process value and associated current reading—manually or automatically. In the latter case, you would insert a sensor into a calibration solution and click on **Use measured mA** to take a measurement. To enter numbers manually you need to use the numeric keypad. *Remember that the display is not a touchscreen and you have to navigate toward the number you want using the arrow buttons.*
7. When you are satisfied that the calibration values, use the Down arrow to select **Done**. (Note: To reach this button you must scroll down past the last button visible.) You will note that the front panel and web interface update the date of calibration.
8. For the case of pulse output flow sensors, calibration requires changing the value of the K-factor, which is done via the numeric keypad.

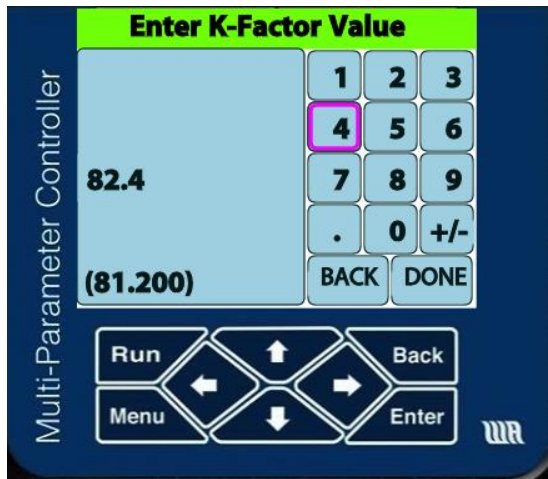

Figure 3-5 - On the left is the numeric keypad for the manual entry of calibration numbers and the K-Factor.

3.4. Setting Relays from the Front Panel

Another operation that may be performed at the front panel is configuring relay set points. Except in the rare case in which there is no access to a local area network, you will have already set up the relay trigger points in the Probe Configuration Wizard. These instructions are for changing those values. You can follow the sequence of screens in

1. First click on **→** to bring up a Detail screen. Unless the probe you wish to edit is the probe #1 you will have to click on **↓** repeatedly until you see the screen for your desired probe.
2. Click on **Enter**. You will be presented with the **Meter Actions** screen. Click on **Relay Set Points**.
3. The next screen shows the relays that have been set. In Figure 3-6 they are “High pH” and “Low pH.” Select the relay you want to modify and click on **Enter**.
4. The next screen shows the current relay set points. In the figure they are the set points for the high pH relay—8.0 for the relay trip point and 7.8 for the reset point.
5. If Password access is turned on then the next screen asks for the front panel passcode. Enter the code from the numeric display.
6. The next screen shows a second numeric display and asks you to enter the new trip point. Click on **Done** when you finish entering the value. In the figure the new set point is 8.2.
7. The next screen (not shown) asks you to either **Cancel** or **Proceed** with your choice. Select and click on Proceed.
8. The final screen shows the new set points. Click on **Run** to return to the default quad screen.

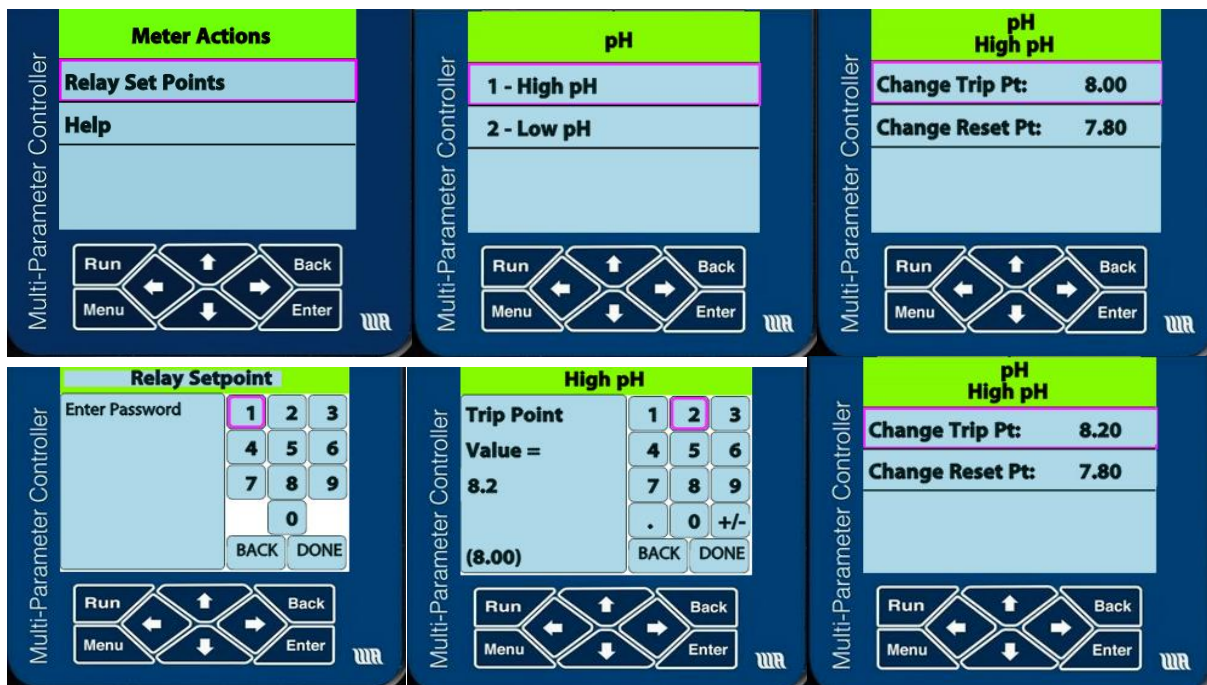

Figure 3-6 – The sequence of screens for changing relay set points from the front panel.

3.5. Saving and Restoring Your Configuration from the Front Panel

Once you have configured the 2300 with probe definitions, relay/alarm set pings and email and server set ups, you can save these settings to the external microSD card via the front panel menu. This is a very feature that is very helpful in case you unit loses its configuration.

1. Carefully insert a microSD card in the rear slot. (Be careful to insert the card into the slot and not in the space above where the card will disappear into the box.)
2. Click on the **Menu** button. The **Backup/Restore** option is already selected. Click on **Backup Configuration**.
3. The next screen will prompt you to **Cancel** or **Proceed**. Click on **Proceed**.
4. The next screen will display a message that the save was successful. If there is no microSD card you will get the message, Backup Failed.

To restore the configuration:

1. insert a microSD card with the desired configuration file folder called BACKUP.
2. Click on the **Menu** button, scroll down to Save/Restore Configuration, and select **Restore Configuration**.
3. The next screen will prompt you to insert the microSD card containing the Backup files and press **Enter** to continue.
4. The IP address of the unit is stored on a Backup file. The next screen gives you the option of either keeping the IP address as it currently exists or using the IP address from the Backup. Select and click on your choice.
5. The next screen prompts you to either **Cancel** or **Proceed**. Select **Proceed** and click on **Enter**.
6. The next screen will display a message that the save was successful. If there is no microSD card you will get the message, Backup Failed.

The Restore utility only works with units having the same firmware build. Upgrades to firmware will not change the configuration inside the 2300, so we suggest saving the configuration to a memory card after a firmware upgrade.

4. Operating the 2300 from a Web Interface

Once you've become accustomed to working with the web-based interface you will undoubtedly find it faster and easier to use it for nearly all operations.

4.1. Setting up an Ethernet Connection to a Network Router

Connecting the 2300 to an existing network with the Ethernet cable enables the 2300 to become a device on the Local Area Network (LAN). This is the network that is visible to everyone inside your facility. All devices that connect to the LAN have a unique address, called an **IP** (Internet Protocol) address. You may manually assign the IP address with a number of your choosing or you can allow

your router to automatically assign the 2300 an IP address. Because the router may change that address this method is called Dynamic Host Control Protocol (**DHCP**).

4.2. Connecting to a 2300 within Your Local Area Network (LAN)

4.2.1. Assigning an IP address via DHCP

The easiest method for configuring the 2300 on a LAN is to use DHCP for assigning an IP address for the 2300. (See Section 2.5) You only need to set the Ethernet connection on your computer or smart device to configure the 2300 via DHCP. The IP address is shown on the front panel during power up or can be seen via the Main Menu under **View System Info (Menu > View System Info)**.

The IP address will look something like 192.168.1.7. Save this address to access the 2300 from your Local Area Network (LAN).

Changing IP addressing from Fixed IP to DHCP or vice versa is an operation that must be done on the front panel. See Figure 4-1.

1. Click on the **Menu** button.
2. Scroll down with the **↓** key to the bottom-most menu item, **Advanced Menu** and click on it.
3. If password protection is enabled (Section 5.7.2), enter the numeric passcode.
4. Scroll down with the **↓** key to **Network Setup** and click on **Enter**.
5. The first menu item is **Network Type**. Click on **Enter**.
6. Select either **Fixed** or **DHCP**. In this section the choice is **DHCP**.

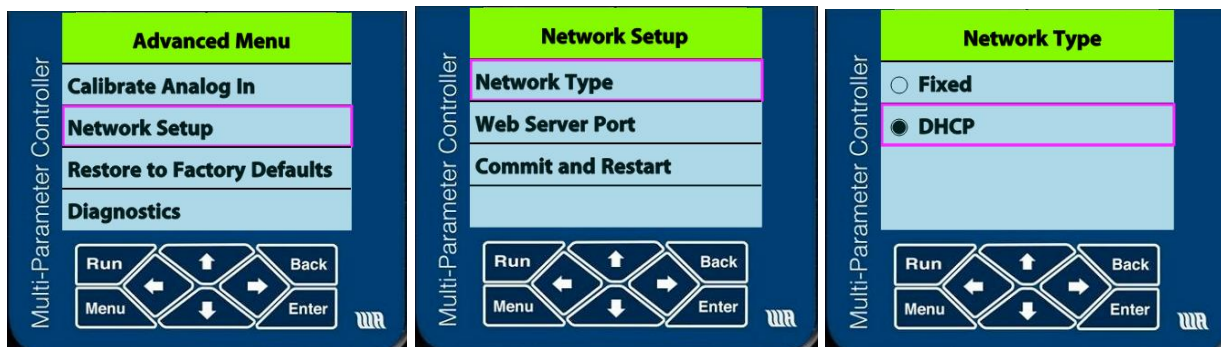

Figure 4-1 - Sequence of menus for toggling between DHCP and Fixed determination of IP address.

4.2.2. Assigning a Fixed IP Address

The main reason for assigning a fixed IP address to a 2300 is to configure it on a wide area network. However, even with DHCP, most routers very infrequently change IP addresses of devices.

To configure the 2300 with a fixed IP address first set the unit up for that mode. Follow the instructions in the previous section. Request an IP address number and a port number from your IT person. *If either one conflicts with an existing device, you will cause much pain and suffering.*

4.2.3. Accessing the 2300 from a Wide Area Network

In order to access the 2300 from a Wide Area Network (WAN), i.e. outside your facility, you will need the address of your router and the port number of the 2300. If you have only one 2300 to be accessed on a WAN, you can use the Demilitarized Zone (DMZ) on your router so that you don't need to set up a port number.

1. You first need the IP address of your router, also called the **External IP**. This is NOT a number that looks like other IP addresses, e.g. 192.168.1.20. To determine the address just open a browser and enter the URL, www.WhatIsMyIP.com. The website will immediately show you the external IP. It will look something like 24.148.220.199.

Entering the external IP address in a web browser should bring up the router's web-based control center. You can also connect to many routers by entering the IP address 192.168.1.1.

2. When you access your 2300 from outside your facility your browser needs to identify your LAN, which it does through the external IP. Every item on your LAN has an IP address. Port forwarding assigns a so-called **port number** to that LAN IP address.
3. Assigning a port number to the 2300 differs depending on your router. This manual won't attempt to cover every type of router configuration. *Furthermore, assigning port numbers to IP addresses can cause serious problems if not done correctly.* That's why we strongly suggest you give this job to an IT specialist. With this warning in mind, here is a general guideline:

The port forwarding number can be any number not taken by another device. However we recommend avoiding any number between 0 and 100 and, preferably, a 5-digit number. Let's say you choose 5000 for the port forwarding number of a 2300. Using the example above, the external IP address of the 2300 then becomes **24.148.220.199:5000**.

4. At the local display click on the **Menu** button. Select **Advanced Menu** > **Network Setup** > **Web Server Port**.
5. Enter the port number (in our example—5000) and click the **DONE** key.
6. Click on the **Commit and Restart** button.

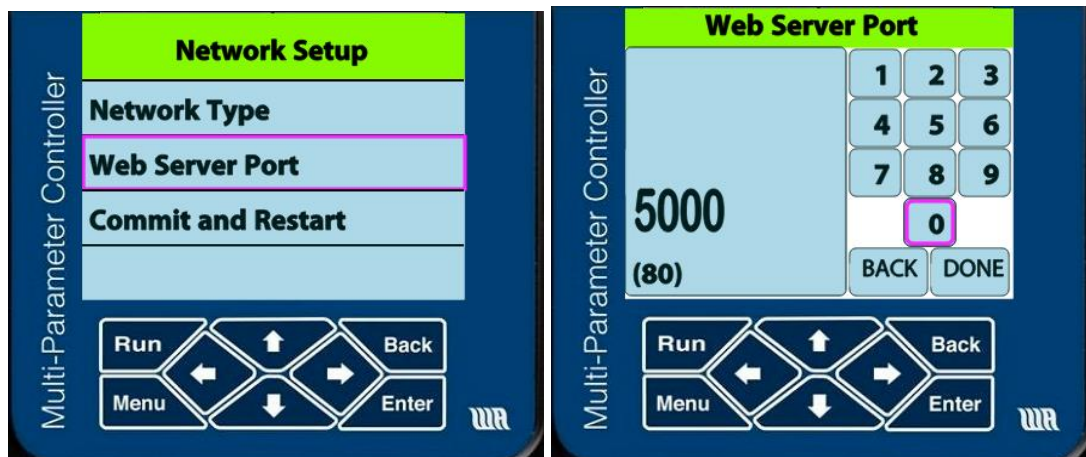

Figure 4-2 - Assigning a fixed (static) IP address,

With the port number configured you can log into the 2300 from anywhere in the world by entering the External IP Address:Port Number (e.g. 24.148.220.199:5000).

If your router supports a Demilitarized Zone (**DMZ**) then you can forgo the use of a port number. The DMZ is a sub-network that isolates its device from the rest of your network. If an intruder attempts to attack your network through a device in the DMZ he cannot penetrate past this sub-network into your LAN. Most routers' control centers will allow you to place one IP address in the DMZ—in this case that of the 2300. To access the 2300 within a DMZ from a WAN you only need to enter the external IP address of your LAN.

4.3. Setting up a Direct Ethernet Connection

A wireless connection between a computer and the 2300 is the most commonly used method for controlling the 2300. For nearly all users this is the configuration that will ever be used. For isolated instances, such as setting-up the 2300 when a network is not currently available, one can make a direct connection between a 2300 and a computer or smart device with an Ethernet cable. Current Operating Systems—OS X, Windows and Linux—connect to an IP device with a regular Ethernet cable but some older OS's might require a crossover Ethernet cable. Note that, after setting up the 2300 Controller, the tethered laptop may be disconnected for operation.

To configure the connection, switch from DHCP (automatic) IP addressing to fixed IP addressing, as described in Section 4.2.2. The fixed IP address you assign to the 2300 must be entered into the computer. Configuring your computer for fixed IP Ethernet communication varies amongst operating systems. We provide basic instructions. To access more specific instructions just search using the phrase "setting a manual IP address" in conjunction with your operating system's name.

Connect the computer to the 2300 via an Ethernet (CAT-5) cable. Apply power to the 2300 Controller. The next three sections show how to set up Ethernet settings on the computer end and the 2300 end.

4.3.1. Settings for MacOS

1. Navigate to its Ethernet settings. Go to **System Preferences > Network > Ethernet**.

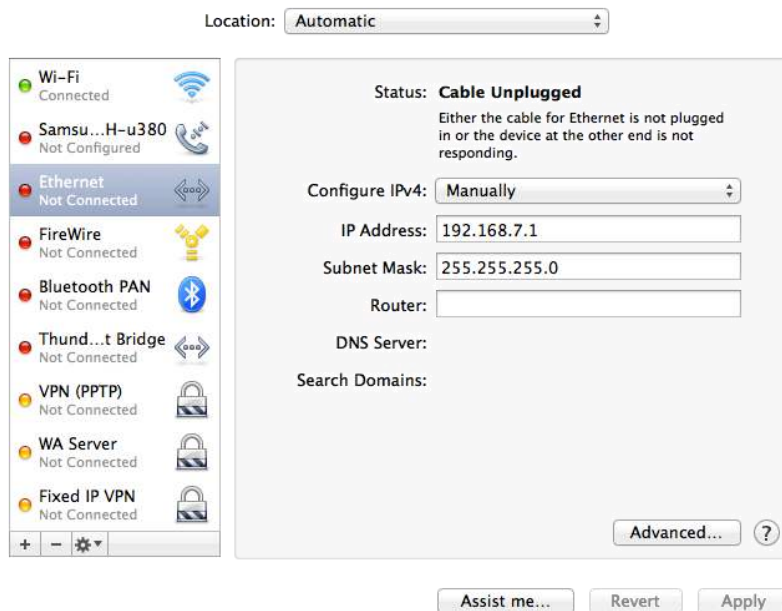

Figure 4-3 - Ethernet configuration with a fixed IP address on a Macintosh

1. Select **Manual** configuration and **IPv4**.
2. Choose an **IP address**, **Subnet Mask** and **Default Gateway**.
 - a. For illustration purposes we will start with the static IP address that will be close to that of the 2300 —192.168.7.7.
 - b. Set the **Subnet mask** to 255.255.255.0.
 - c. Set the **Default Gateway** to 192.168.7.7. Note that the Gateway address is the same as the IP address. That’s because the computer is the gateway to this closed Ethernet network.

4.3.2. Settings for Windows

The settings are found in the control very similar in Windows 7,8 and 10. However getting to the Control Panel differs for the three OS’s. The following instructions are for Windows 10.

1. Go to the Control Panel. On Windows 10 it’s found by clicking on the bottom left Windows



2. Click on the **Settings** icon and, from the Settings window, click on **Network and Internet**.
3. In the Network and Internet window click on **Ethernet**.
4. Click on **Change adapter options**.

- In the Change adapter options window right click on **Ethernet** (or, in older systems, **Local Area Network**). Don't worry if you see the "Unidentified network" in the Ethernet description. (You can also double click on **Ethernet** and click on the **Properties** button in the lower left of the ensuing window.)
- In the contextual menu that appears when you right click on Ethernet choose **Properties**. The Ethernet Properties window will pop up as shown in Figure 4-4.

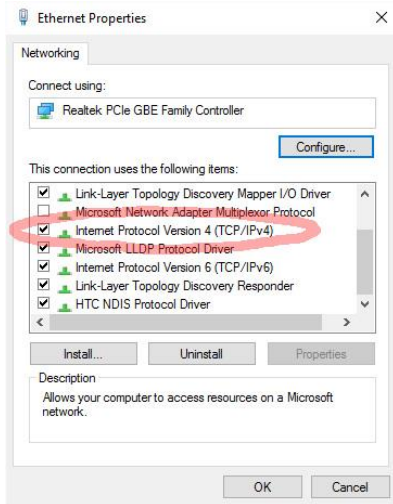

Figure 4-4 - Ethernet Properties window. Choose the IPv4 row.

- Double click on **Internet Protocol Version 4 (TCP/IPv4)**. (You can also single click on the row and then click on the **OK** button.)
- Using the same (arbitrary) numbers as in the previous section for Macintosh settings, enter the numbers you see in Figure 4-5. The **subnet mask** must be set to 255.255.255.0. The **IP address** and **Default Gateway** are arbitrary *but must be equal to each other*.

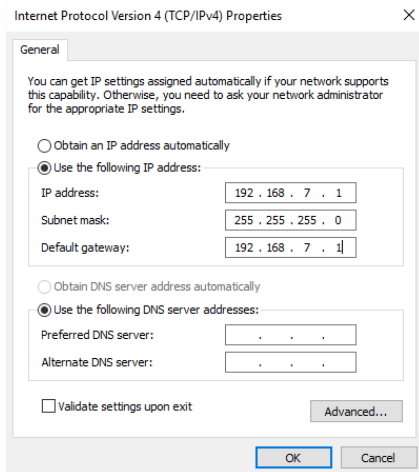

Figure 4-5 - Manual IP v4 settings. The actual values for the IP address and Default gateway are arbitrary but must match.

The IP address and the gateway ID numbers are equal because the computer *is* the gateway.

4.3.3. Settings for the 2300

1. As outlined in Section 4.2.1, set the 2300 Network to **Fixed**. (**Menu > Advanced > Network Setup > Fixed**).
1. There are three fields in which to enter numbers. For illustration purposes we use the following set of numbers: The right-most digit of the IP address can be any digit other than 1, which is the digit for the Gateway.
 - a. **IP Address:** 192.168.7.7.
 - b. **Subnet Mask:** 255.255.255.0.
 - c. **Default Gateway:** 192.168.7.1. This is the IP address of the connected computer.
2. When complete, select and click on **Commit and Restart**. A confirmation screen will appear.
3. Select and click on **Confirm** and click on **Enter**.

4.3.4. Log In!

With the proper Ethernet settings on the computer, or any smart device, and the 2300 you can now bring up a browser window and enter the IP address. In the example above it's 192.168.7.7. The browser window should present you with the login window for the 2300 and prompt you for your username and password.

4.4. Accessing the 2300 from a Private Wireless Network

There are installations for which an Ethernet LAN is not available. With the 2300's web server it only takes an inexpensive wireless router to connect a computer, smart phone or tablet. Aquamatrix sells a very compact, inexpensive router made by Tenda to set up a wireless network. If you purchased a 2300 with this device then the router and the 2300 will already be configured and ready to go.

The following instructions to connect your smart device to the 2300 are specifically written for the Tenda router. A different wireless router may configure differently.

1. Connect the router to the 2300 Controller via a standard Ethernet cable. Connect the AC adapter to the router to power it.
2. Set the router to **WISP** (Wireless Internet Service Provider) mode.
3. On your computer search for available wireless networks. You will see a list of networks, one of which will be for the router's network. The default name of the network for the Tenda router is "**Tenda**." You may wish to change the name. Connect to that network. *Be aware that you will no longer be connected to the Internet.*
4. Power up the 2300. After the Aquamatrix splash screen shows you will see the IP address that the router assigned to the 2300. If you miss it you can recall it at any time simply by clicking on the **Menu** button on the keypad and then clicking **View System Info**. The IP address will be on the second line of the System Information screen.

5. If the 2300 does not connect to the private network then you will see a screen with the title **No IP Address Assigned** followed by the message, **The system has a network cable inserted but cannot get an IP address. To do this, change type to fixed IP on next page. See manual for more. Press [Enter] to continue.**
6. If you see this screen then simply press **Enter**. You will then see a screen with the title **Select Network Type**. Enter **Try DHCP Again**.
7. On your smart device WIFI connected to the Tenda network, open a browser and type in the IP address. The username is "**admin**" and the password is "**aquametrix**."

5. Configuring the 2300 via the Web Interface

Enter the unit's web page address into a web browser connected to the same network as the 2300 Controller or, if not using a network, into the computer's browser connected to the 2300 Controller via the Ethernet cable. A web page address will look something like <http://192.168.1.7>. A login dialog box will appear, asking for user name and password.

The password is used on the web to restrict access to administration functions to the system. The default username is **admin**, and the default password is **aquametrix**.

The 2300 and the probes are configured using the five buttons along the top of this screen. Their functions and their submenus are described below in Table 2. Note that there are two other levels of password protection, that don't access everything that the admin level does. See Section 5.5 for a description of user levels.

Table 2 - Menu Items Available to an Administrator

Menu Item	Function
Probe Status	Displays the current values of the sensors along with recent history and action status.
Remote Display	Displays a simulated image of the current front panel of the 2300 with active buttons. Clicking on one of the 8 navigation buttons changes the screens and moves the cursor just as if these buttons were being pushed on the actual unit. These actions update the unit accordingly, which in turn updates the simulated display. Try to remember to leave the Remote Display in RUN mode!
Logs	
Data Logs	Brings up the list of daily data logs in memory, allowing data to be emailed, downloaded, or deleted. Also does setting of the period for logging

Daily Logs	Brings up the list of annual data logs with three datapoints per day: min/max/average. Allows data to be emailed, downloaded, or deleted.
Alarm Logs	Brings up the list of alarm logs in memory, can be saved or deleted
System Logs	Brings up the list of system logs in memory, including errors, jscripts, and system access. These can be viewed, saved, or deleted
Setup	
Probe Configuration	Set up sensors, alarms, relays, and notifications.
User Maintenance	Set up users and passwords.
Data Logging Config	Set up data logging parameters
Network Setup	Set up web server, TFTP server, and emails.
System Config	Miscellaneous configuration options
System Documentation	System doc file
Advanced	Miscellaneous
Logout	Logs the current user out of the system after a confirmation

5.1. Probe Status

The Probe Status button does not bring up a menu of options. It displays all enabled probes, their names, values, alarm and relay set points, and graphs showing the history of values for the previous 15 minutes. Logging into the 2300 via the web brings up the Probe Status page, an example of which is shown in Figure 5-1.

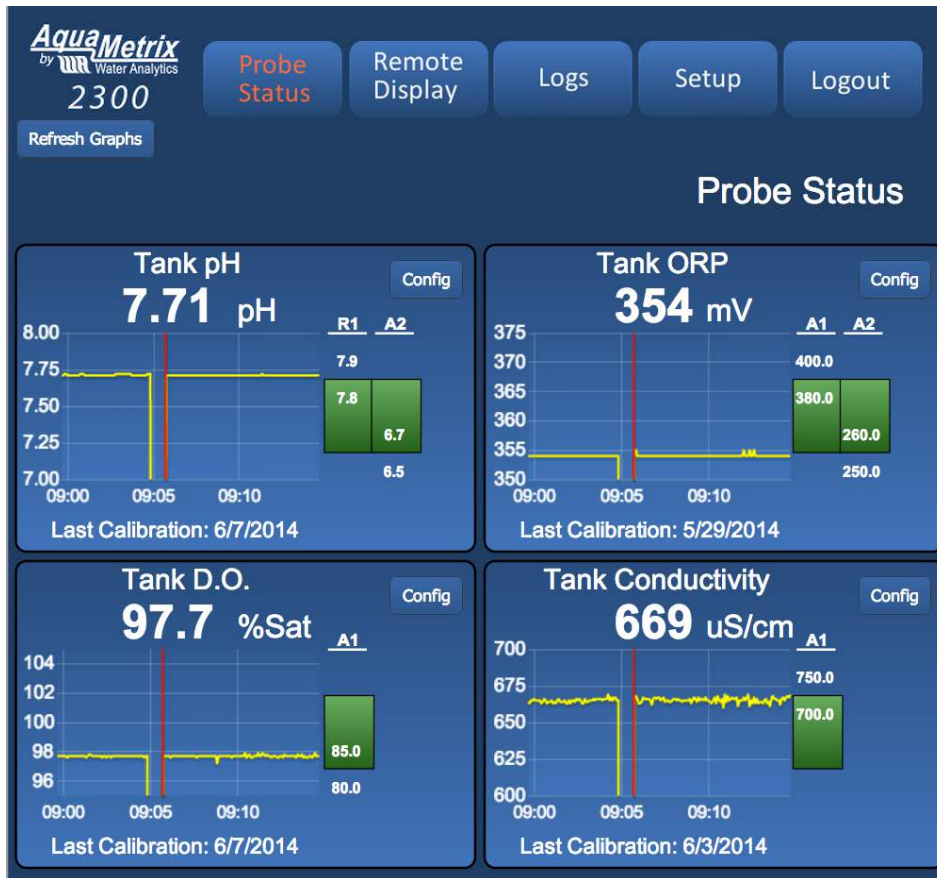

Figure 5-1 - Probe Status menu showing four analog sensors (pH, ORP, conductivity and Dissolved Oxygen)

Clicking anywhere within a graph allows one to view a probe history, as shown in Figure 5-2. Slide the cursor on the bottom to look back in time.



Figure 5-2 – Clicking anywhere within a graph of the Probe Status menu brings up the time history.

Clicking on the **Config** button in any quadrant brings up a window with options for setting the limits of the y-axis to optimize the scaling. One can also acknowledge an alarm that has been triggered.

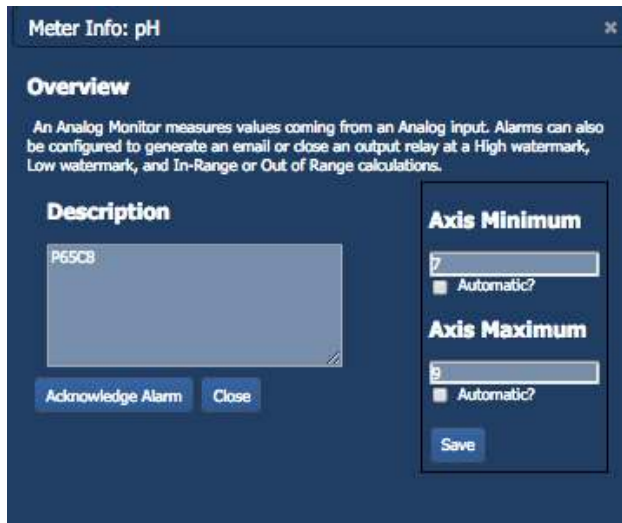

5.2. Remote Display

This button presents a duplicate view of the front panel display. Any change in the web view is mirrored in the front panel view, and vice versa. This option is typically not needed.

5.3. Logs

The Logs button allows one to download the three types of logs:

5.3.1. Data Logs

One data log exists for each day. Click on any date to start a download the CSV file for that day. To email the file, click on the checkbox to the left of the date and click on **Email**. Select the email address (set up in Setup > Network Setup > Email Setup > Email TO Addresses.) In order to email data logs you must enable email delivery in the **Data Logging Configuration Wizard** (Section 5.5.1).

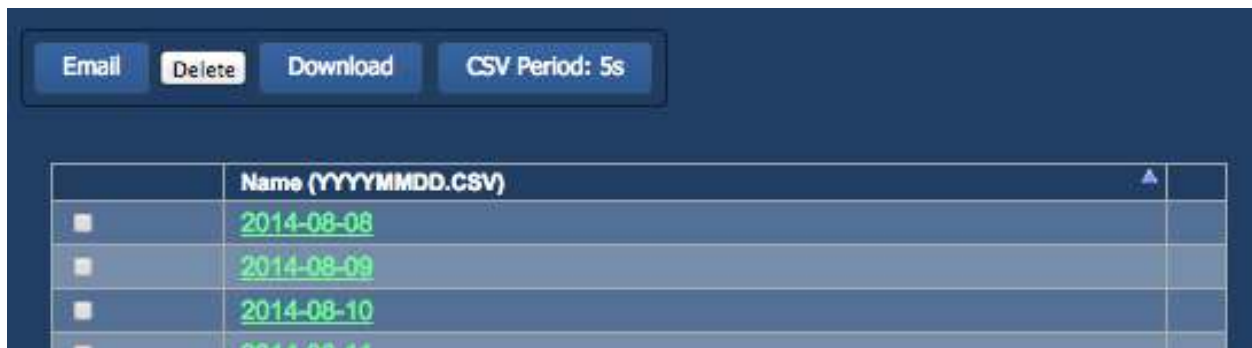

Figure 5-3 – Part of the Data Log window. Clicking on any date bring

5.3.2. Daily Logs

One data log exists for one year. Each day is represented by three points: min, max, and average for that day. This can be used to track seasonal trends.

5.3.3. Alarm Logs

Alarm logs are downloaded as CSV files. They track each time an alarm is triggered for a probe, and when acknowledged.

5.3.4. System Logs

There are up to seven system logs, described below.

- **System Access Logs** store every configuration that is changed for the AquaMetrix 2300 Controller. Entries are added for system starts and shutdowns, sensors enabled or disabled, and users added or deleted. In addition, each time a user logs into the browser interface, that event is logged. The log file size is limited to a maximum of 0.5 Megabytes and when that size is reached, it is renamed and a new file is created.
- **Email Message Logs** store the time, subject, TO address and message text for each email sent by the system, along with the action that triggered it. This is useful to track Alarm emails to ensure they were sent. The maximum number of alarm logs stored is fifteen days of data. To download an alarm log just click on the name of the desired log. The current Email message file is named **EMAILMSG.TXT** and is formatted as a text file. The log file size is limited to 1 Megabyte and, when that size is reached, it is renamed to a backup name and a new file is created named **EMAILMSG0.TXT**. Only one backup file is saved.
- **Web Server Error Logs** store any request that generated an error from the internal web server.
- **Jscript Error Logs** store any JavaScript errors.
- **Web Server Access Logs** store each request sent from a web browser to the AquaMetrix 2300 Controller. It is not enabled by default but can be activated from the web server Setup / Network / Web Server setup page. It is only necessary when trying to diagnose web access issues.

These logs are available for downloading under the Logs button on the main web menu.

5.4. Setup

Configuring a probe with the 2300 using the web interface is easy and fast. The Configuration Wizard will guide you through the entire process. Set-up involves naming the probe, choosing the correct analog input, calibrating the probe and setting alarms and relays.

To start the Configuration Wizard choose **Setup** from the top-level menu and click on **Probe Configuration**. The **Probe Configuration** window is shown in Figure 5-4. Clicking on any probe or placeholder for a probe initiates the wizard. Note that you can also delete, disable or enable any probe simply by checking the box in the left hand column and clicking on one of choices on the bottom row of buttons.

This page is where you configure the parameters for monitoring and... There are eight channels below, each occupying one row numbered... order that they are displayed on the front panel and on the Probe Sta... can display one Probe input, which may be one of the remaining four... digital, or one of the virtual functions such as Totalizer, Differential o...

Click on a Probe name to edit it, which includes calibration and assign... such as alarms, relay contro, or email message. To change the inp... a used input to another Probe, you must first delete the Probe by clic... and then clicking on the "Delete" button below.

Display #	Used By #	Name	Probe Type	Rel
1	-	Tank pH	Analog 1	Hi
2	-	Tank ORP	Analog 2	Hi
3	-	Tank D.O.	Analog 4	Lo
4	-	Tank Conductivity	Analog 3	Hi
5		Click here to add new Probe		
6		Click here to add new Probe		
7		Click here to add new Probe		
8		Click here to add new Probe		

Enable Disable Delete Change Display Order Exit

Figure 5-4 - Probe Configuration page

There are 16 software channels available for configuration. These inputs include 4 (or 8) analog inputs, pulse inputs and any combination of probes whose outputs combine to create a function (virtual probes).

To configure a new probe, or reconfigure an existing one, click on its name. For a new probe the "name" listed is "Click her to add new probe." The Wizard will guide you through 5 or more pages setup that includes instructions. Settings are not cemented until a final **Submit** is clicked. The Wizard also keeps track of the last time a calibration was done on each probe, the date of which is displayed on the detailed probe screen on the unit's front panel.

Probe 1 Configuration Wizard (Type: Analog Monitor - Analog Input 1)

This page allows you to review all information entered. Please review and press [Submit] when done.

Enter Probe Name
pH

Scaling/Calibration Type
Linear (2 points)

Probe Enabled?

Low milliAmp Value
8.63 Read mAmp Value

Scaled value displayed at low input Value
4.00

High milliAmp Value
12.22 Read mAmp Value

Scaled value displayed at high input Value
7.00

Digits after Decimal Place
1

Number of Significant Digits
3

Damping Seconds
0

Units of Measure
pH

Probe Description
Manage User-entered Units at Setup/System Configuration/Units List

Action 1 Name
Pump

Action 1 Type
Low Relay (NO)

Relay Number
Display-Only Select Relay

Trip Point
5.0

Reset Trip Point
5.5

Advanced

Delay Alarm (seconds)
Before: 0
After: 0

Cycle Time (seconds)
On
Off

Email Notification?
 No Email
 Send at Control Trip Point

Figure 5-5 - The Summary page displays the parameters set and allows the user to change them.

To set up a new probe, click on one of the **Click here to add new Probe** boxes, and follow the Wizard's instructions. Drop down menus are used for multiple-choice items, and the Wizards include pictures of the unit's rear to facilitate correct wiring (look for **Select Input** or **Select Relay** buttons).

After configuring a sensor, your inputs are summarized on a single screen, as shown on Figure 5-6. Click **Submit** to lock in the configuration and enable the sensor. The **Probe Configuration** screen returns so that you can configure another sensor.

Chapter 6 will discuss probe configuration in greater detail.

5.5. User Maintenance

This menu item allows you to set up users and grant each with one of three levels of permissions.

Users are added, changed or deleted from the Setup/User Maintenance selection menu. Each user name must be unique in the system and can contain letters or numbers. The password may only contain letters or numbers, and a PIN may be added at this point for front panel (LCD) access. User access to the 2300 is logged, allowing traceability of changes made to the controller by username and by time.

There are three different access levels provided by the AquaMetrix 2300:

1. **Administrator** – Can view all reports, add, change or delete Sensors, change system settings, and add or delete Users.
2. **Editor** – Can view all reports, change Set Points for Sensor Relays, Acknowledge Alarms and Zero Summarizer Counters
3. **User** – Can view all reports and logs but cannot change any configuration or Acknowledge Alarms or Zero counters

By default, there is one user in the system, named **admin**, who has the Administrator access level. During first-time startup, the administrator is asked for a new default password for this user.

At any time, an Administrator may add additional users to the system and assign any of the above access levels. Although an Administrator creates each user and their password, each user is able to subsequently change their individual password.

Note that web users will be logged out automatically after a specified interval, selected from the **Setup>System Configuration>Browser** Settings menu.

NOTE: It is recommended that the **admin** password be changed from the default value to a different password to prevent unauthorized access to the system.

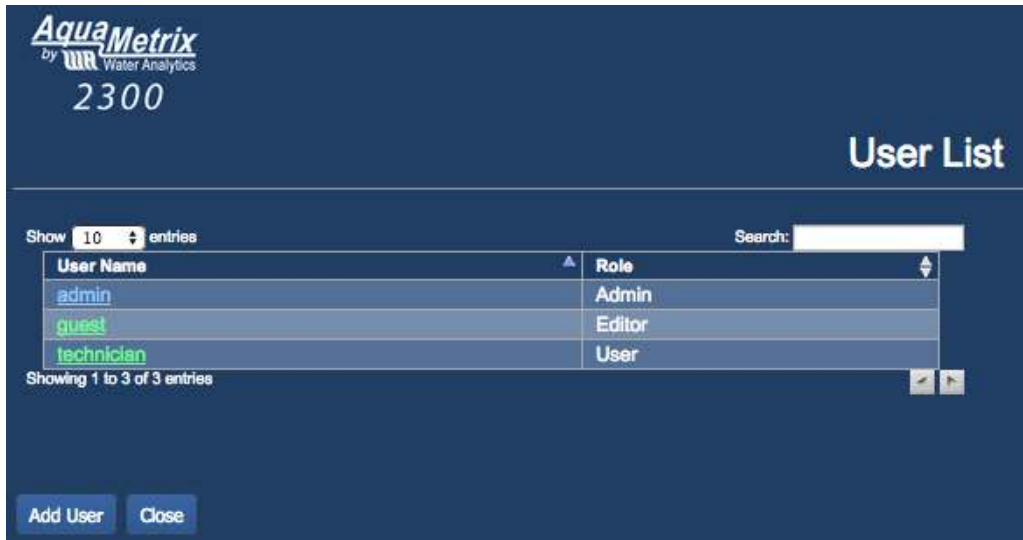

Figure 5-6 – User Maintenance window showing three users that have been set up, each with a different user level.

5.5.1. Data Logging Configuration

Data logging is an indispensable feature of the 2300 and one that you will use extensively. Data logging sends all sensor information and all configured digital input data to a central CSV-based log file. The 2300's default values for data logging are:

- Maximum days of Logs to Keep: 15
- CSV Logging Frequency: 5 seconds.
- Delivery Method: Manual Download from Browser.
- Output only Configured Probes – Checked.
- Output Changes Only – Checked.

The **Data Logging Configuration** Wizard allows the user to change these values. Page 1 of the Wizard determines the number of days for which the 2300 keeps log file. Page 2, shown in Figure 5-7, determines the **Logging Frequency** in seconds and the **Delivery Method**, either via **Manual Download** from your browser or **Email Delivery**. Email delivery can be set to periodically email the data log file every day at midnight, or more often.

Page 3 is the summary page and is shown in Figure 5-7. This page allows you to change any of the five options.

Data Logging Configuration Wizard

Logging Configuration Summary

This page allows you to review all information entered. Please review and press [Submit] when done.

Max Days of Logs to Keep (0 for unlimited)
60

CSV Logging Frequency (seconds)
10

Delivery Method
Manual download from browser

Output only Configured Probes?

Output Changes Only?

Cancel Back Submit

Figure 5-7 - Summary of Data Logging parameters

Keep in mind:

1. The limit to the amount of data storage is limited by the size of the microSD card and the logging frequency. If the probe(s) changes value only on a minute timescale you are better served changing the logging frequency to approximately 60 seconds.
2. The option of emailing a data log can be invaluable if you are working through a system start-up or a technical problem.

5.6. Network Setup

This set of menus establishes communication of the 2300 over a local area network. It also sets up e-mail. There are four sub-menus.

5.6.1. Ethernet Configuration

The 2300 contains its own web server, which sends web pages through your local area network via an Ethernet cable connected to a router. The easiest way to enable this is to choose Dynamic Host Control Protocol (**DHCP**) to allow the router to choose an IP address for the 2300. To do so simply make sure that the checkbox for **Use DHCP** is checked.

Your systems administrator may choose to manually DNS servers in the entry field provided.

5.6.2. Web Server Configuration

The main item in this window is the port selection through which the web server communicates. This is typically **80**.

There are two checkboxes that enable the Error and Access logs.

5.6.3. Modbus/TCP Server Setup

Modbus communication occurs through the Ethernet cable using TCP. This window allows you to choose the port number, enable access over Modbus/TCP of the error and access logs, and whether you wish to restrict communication to read-only.

5.6.4. Email Setup

Sending Email alerts is an invaluable feature of the 2300. There are two steps to setting up Email alerts:

1. Setting up the Email SMTP server information
2. Setting up the Email receiver information

There are four submenus for doing this.

5.6.4.1. SMTP Connection Setup

For your convenience AquaMetrix has set up a Gmail account that you can use free of charge.

The settings are as follows. If you set up your own email account then the following setup guide still applies but your SMTP settings will differ.

1. In the Setup menu click on **Network Setup**.
2. Click on **Email Setup**.
3. Click on **SMTP Connection Setup**.

The next screen is just a guide to the actual setup. Read it through and click **Next**.

4. The first screen, Figure 5-8, sets up the mail server. To use the complimentary Email account enter the information as shown in the figure and listed here:

The screenshot shows a window titled "SMTP Connection Wizard" with a sub-header "2. Basic Information". It contains the following fields and options:

- SMTP Server Address: smtp.gmail.com
- SMTP Server Port: 587
- Global FROM Address: aquamatrix2300@gmail.com
- Does your SMTP Server require authentication? Yes No
- Does your SMTP Server require StartTLS? Yes No
- Buttons: Cancel, Back, Next

Figure 5-8 - The Basic Information page of the SMTP Connection Wizard configures the Email server.

5. The next screen asks for the username and password. For the complimentary Email account enter the text as shown below:



6. The fourth screen in the Wizard is a connection test to ensure that your SMTP values are correct.
7. Click on the **Test Email** button. If successful you will see a message similar to the one in Figure 5-9. If you receive an error message then go back through the Wizard and check the email account settings. See the next section to resolve a possible issue associated with Gmail accounts.

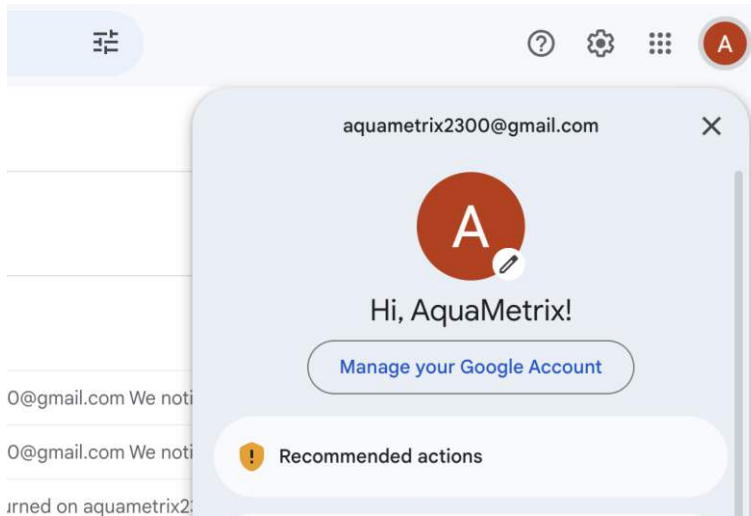

Figure 5-9 - Email configuration Wizard screen showing successful test of the Email server.

5.6.4.2. Note for Gmail Users

Google views email originating from a device like the 2300 as suspicious activity and is likely to block it. In order to prevent that from happenings you must allow “less secure apps” in the security settings of Gmail. To do so one first needs to enable 2 factor authentication. If the 2FA is already enabled, go to the step 6, otherwise start form step 1:

1. Open GMAIL account in a browser
2. Click on the circle in the top-right corner (in the example below it has letter “A”, it’s usually the first letter of the account name)



3. Click on "Mange Your Google Account" button. A new tab will open showing GMAIL settings.

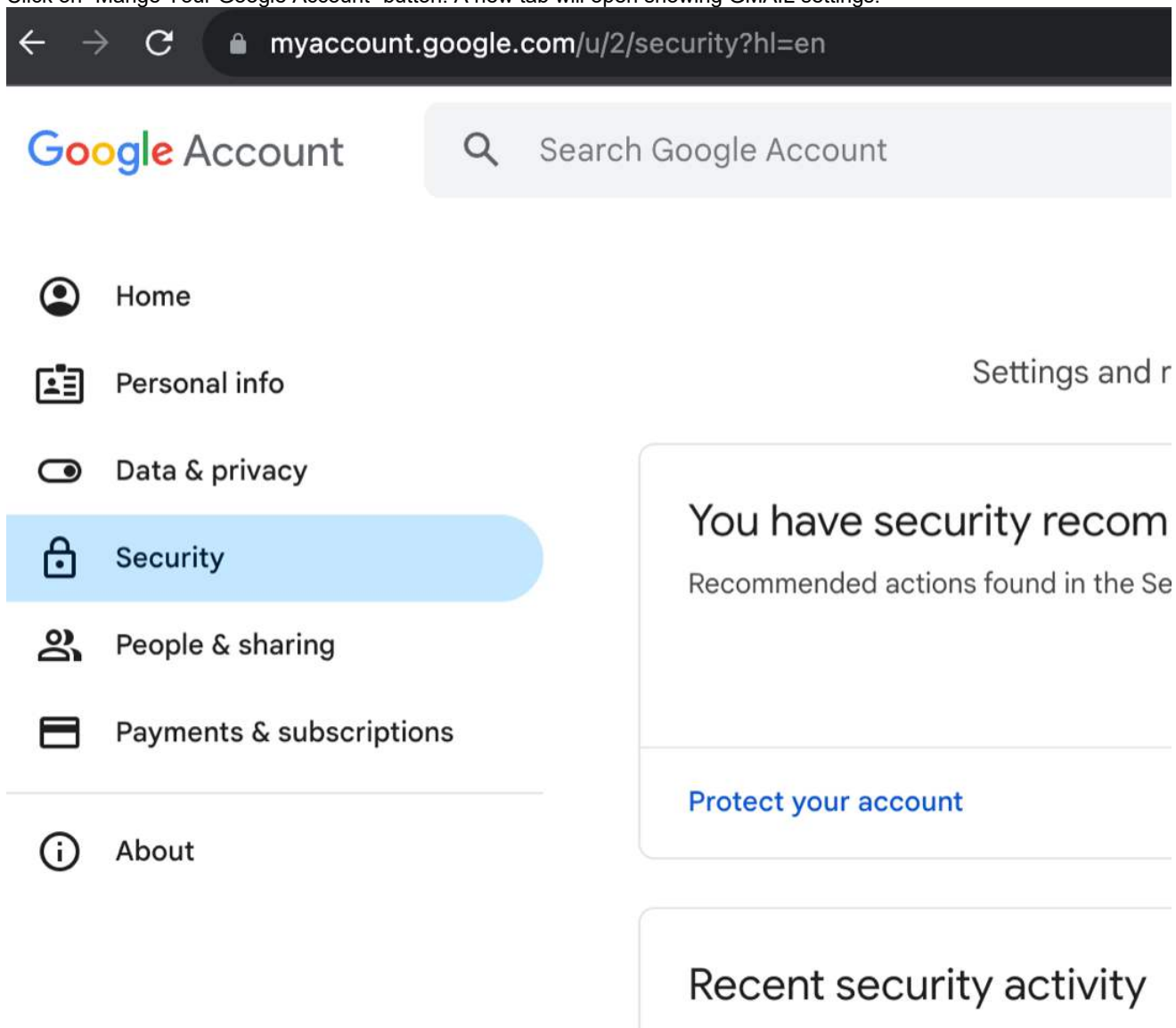

4. Select "Security" button.
5. Scroll down for "How you sign in to Google" section

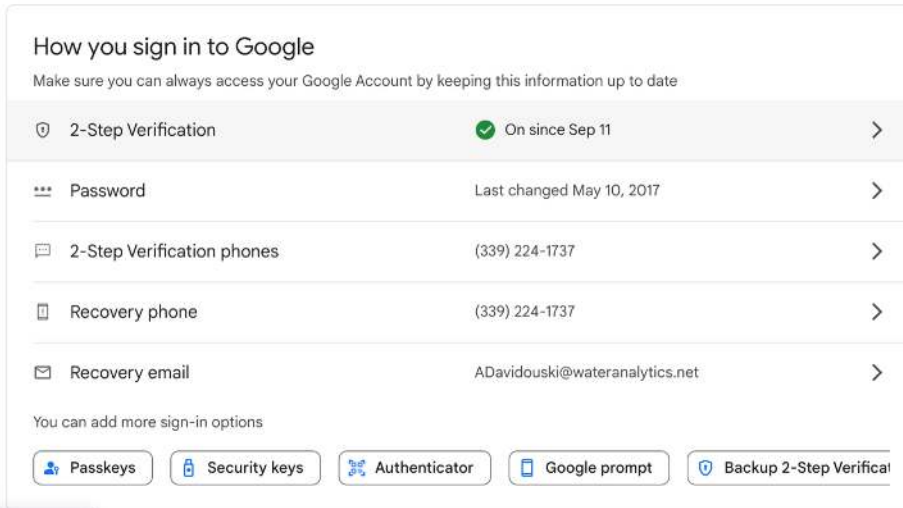

6. Select 2-Step Verification and follow the instruction on that page.
7. Once 2FA is active, you can generate an app based password. To do so, navigate back to the "2-step Verification" menu (Manage Your Google Account —> Security —>2-Step Verification)
8. 8. Scroll all the way down and click on the arrow in the "App passwords" field

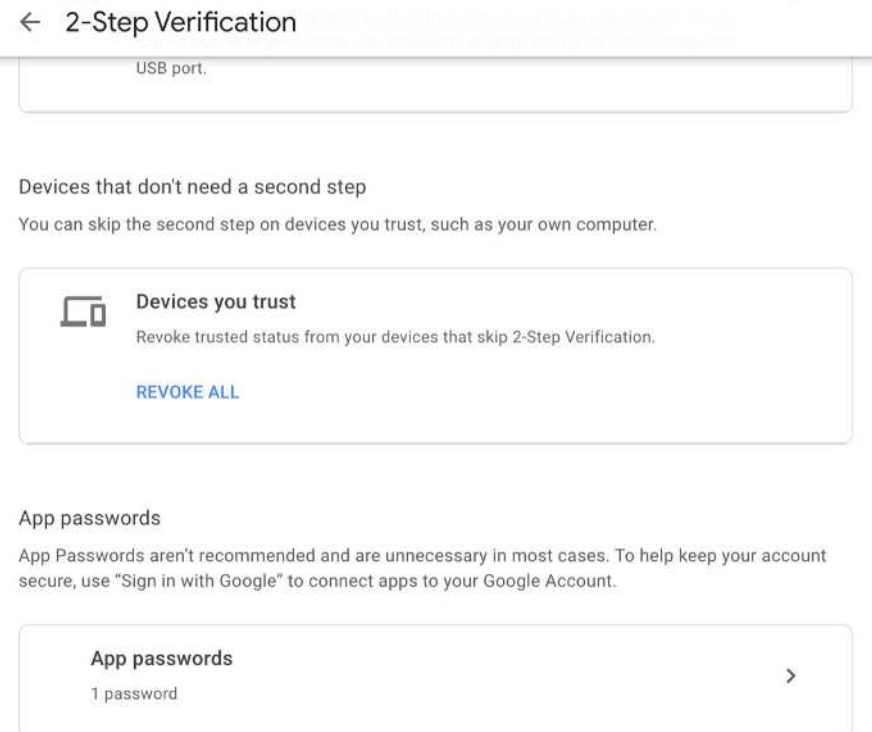

9. Add a new app by typing a name (could be anything, in my example it is AM-2300) and click "Create"

← App passwords

App passwords help you sign into your Google Account on older apps and services that don't support modern security standards.

App passwords are less secure than using up-to-date apps and services that use modern security standards. Before you create an app password, you should check to see if your app needs this in order to sign in.

[Learn more](#)

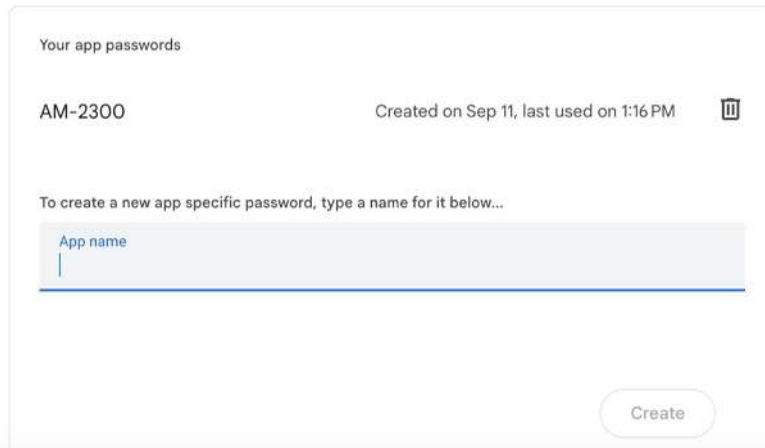

Your app passwords

AM-2300 Created on Sep 11, last used on 1:16 PM

To create a new app specific password, type a name for it below...

App name

Create

10. A popup window will appear, and a new 16-digits password will be generated. Write down the password (skip spaces only 16 letters are used) as it won't be displayed ever again, and you can't change it. You can, however, generate a new password any time in the future in case you lose it.

5.6.4.3. Send Test Email

The Test Email function allows you to assure yourself that you will receive an Email alert. Simply choose from an address from the dropdown menu listing of all the Email receiver addresses you set up in the **Email To Addresses** menu. Click on **Send Test Email** and look for the message to appear in your inbox.

5.6.4.4. Email Message Setup

In this wizard you can set up very specific messages for your alerts. To create generic messages go to **Setup > Network Setup > Email Setup** (as before) and click on **Email Message Setup**. A new window appears that will allow you to draft as many alerts as you desire. Figure 5-10 shows two Email messages.

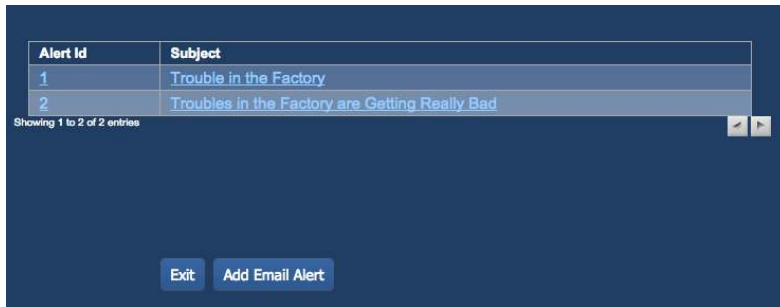

Figure 5-10 - The Email Message Setup allows you to set up as many email messages as you wish.

Most wireless phone carriers have email addresses, which allow the content of emails to be sent to a phone as a text message. Emails sent by the 2300 may therefore be sent to most cell phones for instant action, eliminating the delay of checking one's email. To use this feature you must know the cell phone carrier of the recipient and the domain name of the carrier's email receiver. A list of postfixes for some of the most common US and Canadian carriers is listed in Table 3.

Table 3 - Email domain names for common hosts

Carrier	Email Address
Verizon Wireless	@vtext.com
AT&T	@txt.att.net
T-Mobile	@tmomail.net
Sprint	@messaging.sprintpcs.com
MetroPCS	@mymetropcs.com
Rogers Wireless	@pcs.rogers.com
Telus Mobility	@msg.telus.com

If you want to send an email alert to a Verizon cell phone, whose number is 978-234-5678 then configure the email recipient to be 978-234-5678@vtext.com. If your provider is not on this list, search the web or ask your cell phone provider for the text email for your service.

5.6.4.5. Email To Addresses

The Email SMTP server is preloaded with a default configuration so that you can start sending Email alerts immediately. You only need to specify Email addresses to which these alerts are sent. The **Email TO Addresses** allows you to set up multiple email addresses to send notifications and logs. Figure 5-11 shows two Email addresses that have been set up to receive alerts.

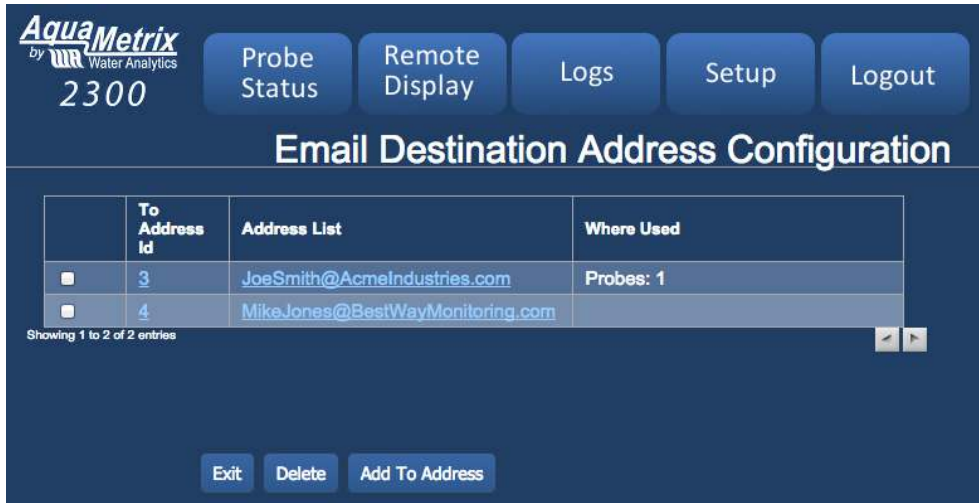

Figure 5-11 – The Email TO Addresses menu allows you to enter as many user e-mail addresses as you wish.

5.7. System Configuration

5.7.1. Name & Time Configuration

This page allows you to customize the name of the 2300, identifying the unit by location or function. Time zone, date, and time are also set here.

The time of day sets automatically if the 2300 is connected to the web via an NTP time server. The NTP server is already entered (pool.ntp.org). You may set the time manually if you wish.



Figure 5-12 - Name & Time Configuration allows you to set the 2300 name and time of day.

5.7.2. LCD Configuration

This simple menu activates password protection when operating the front panel.

5.7.3. Unit Configuration

During the configuration of a probe the user must specify the units of measurement. The 2300 already has units that are already installed in the firmware this screen allows you to add as many as 9 custom units.

5.8. System Documentation

This section is reserved as a repository for documentation such as manuals. Files are loaded with the firmware upgrade. Expect future upgrades to include a manual and quick-start guide.

5.9. Advanced

5.9.1. Modbus Address List

This is a non-editable list of Modbus addresses.

5.9.2. List Logged In Users

This is the most useful of the advanced menus as it reveals who is logged into the 2300.

5.9.3. Prepare for Shutdown

This command executes an orderly shutdown by closing log files, turns off relays and disables probes.

5.9.4. Restart System

No explanation needed here.

5.9.5. Restore to Factory Defaults

This command resets the unit to its factory status. This renders the 2300 preconfigured for 4 analog probes and 3 pulse input probes. You have the option of deleting log files. It is not the same as restoring a saved configuration.

6. Configuring Probes

6.1. Overview of Probe Types

There are two types of probes—real and virtual. Real probes are either analog probes or pulse input probes. Virtual probes perform functions on the output of real probes.

- **Analog probe** — This is any sensor that outputs a 4-20 mA signal. The standard card has 4 slots for analog probes.
- **Precision Pulse Probe** — This is a pulse output sensor—likely a flow sensor—that connects to either of the first 2 inputs (**dig in 1** and **dig in 2**) of the pulse input connector. It measures time between each waveform and calculate the frequency. The precision pulse probe can measure input signals up to 20 KHz with a resolution of 100 ns.

- **Pulse input Probe** — This is also a pulse output probe—also likely a flow sensor—but it calculates the frequency of the output probe by counting the number of pulses in one second. For low frequency pulses it is not as accurate as the precision pulse probe input. In general this input should be used for pulse output probes only when the 2 precision inputs are taken.

The next four probe types are all virtual probes. All but the analog differential probe use functions from the pulse input sensors to create three types of totalizers.

- **Totalizer Probe** — This is a flow totalizer that takes input flow data from any probe.
- **Analog Differential Probe** — This probe subtracts the readings from two analog probes. It is used often as a differential pressure sensor.
- **Formula** – This option allows you common math operations between already configured probes (sum, difference, ratio etc).

Since the two major types of probes— analog and pulse input—are different there will be separate sections for each. The following sections will walk you through the Probe Setup Wizard in detail for the analog probe. Following detailed instructions for the setup of an analog probe there will be a separate section for configuring a pulse input probe and another for configuring a virtual probe. These sections will be shortened since many of the instructions for their setup will have already been covered in those for an analog probe.

6.2. Adding an Analog Sensor

Section 5.4 provided an overview of configuring sensors. This section goes through the **Probe Configuration** Wizard in greater depth, including the setting of relays and alarms and virtual probes.

To get started go to **Setup > Probe Configuration**. Figure 5-4 shows the complete first page of the Wizard, with the first slots occupied by analog probes. Figure 6-1 shows a section of the page with only the first two slots occupied by two probes (pH and ORP).

■	Display #	Used By #	Name	Probe Type	Relays	Probe Status
■	1	-	pH	Analog 1	High Alarm	Enabled
■	2	-	ORP	Analog 2	High ORP	Enabled
	3		Click here to add new Probe			Not Configured
	4		Click here to add new Probe			Not Configured

Figure 6-1 – A section of the first page of the Probe Configuration Wizard showing that slots 3 and 4 are available for probes.

To add a probe, select an open slot from the table—likely #3 in this example—and click on **Click here to add new probe**. (Once the probe configuration is set and submitted, this step cannot be repeated without deleting the slot to start over.)

6.2.1. Probe Selection

After clicking on the available probe slot you will be asked to select a probe type. Select **Analog Probe** from the drop-down menu and click on **Submit**.

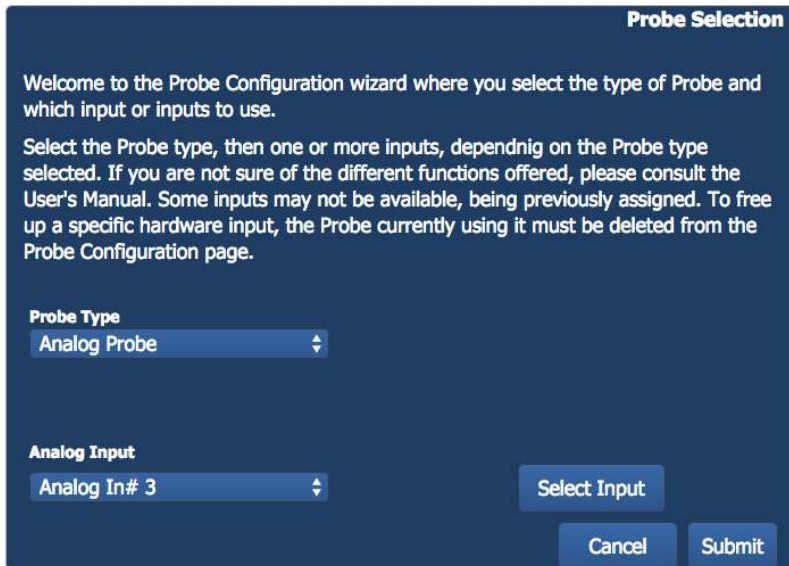

Figure 6-2 – The first window of the Probe Configuration Wizard contains the probe type and input. The input drop-down menu appears after you choose the probe type.

When you do so the same window adds a second drop-down menu to choose the input based on the analog probe. The **Select Input** button brings up a picture of the back of the unit showing the connectors. The connector that is relevant to the type of probe chosen has a yellow rectangle surrounding it. Click on **Submit** to lock in your choice.

The next window starts the process of defining the probe, scaling it and setting actions (relays and alarms).

6.2.2. Probe Information

In the **Enter Probe Name** field write a short descriptive name for the probe. In the example shown in Figure 6-3, the probe is simply titled “pH.”

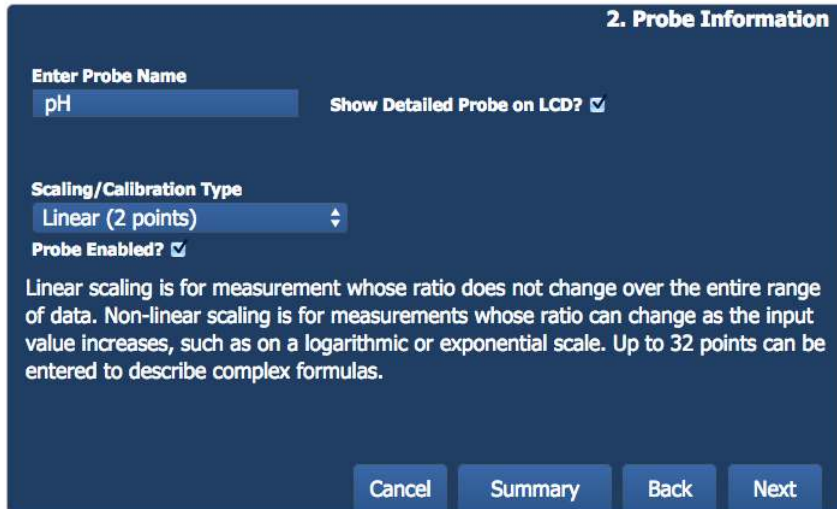

Figure 6-3 – After choosing the connector to which the probe attaches choose a name for the probe and the type of scaling.

6.2.3. Scaling

Strictly speaking, one **calibrates** a sensor that outputs a direct 4-20 mA signal but **scales** a transmitter that is connected to a probe, the latter of which has already been calibrated. In the case of a direct output probe, e.g. a pH sensor, the calibration requires the use of calibration standards—in the case of pH probes standard buffers. In the case of the latter, the signal coming into the 2300 simply needs to be scaled to translate current readings to process variable units. *However, since we make no distinction in this manual between sensors and transmitters, we use the two terms interchangeably.*

6.2.4. Linear Scaling/Calibration

Analog probes are scaled/calibrated using linear (2-point) scaling or non-linear (multiple points) scaling. In most cases 2-point scaling is sufficient. Keep in mind that scaling using multiple points does not apply a best-fit curve through the points. It simply connects the individual points and interpolates between two points to generate a number.

If linear (two-point) calibration is chosen the screen shown in Figure 6-4 appears. A two-point calibration requires two calibration standards in which the probe is immersed. The procedure is simple:

1. Place the probe in the first calibration solution. Allow at least 30 seconds for the probe to equilibrate—more if the probe has been sitting in the process and the temperature differs from the temperature of the calibration solution. Click on the top **Read mAmp Value** and take a measurement of the current. To insure that the probe has equilibrated take at least one additional current measurement. When you are satisfied that the measurement is stable enter the process value in the box, **Scaled value displayed at low input Value**. For instance, if the probe is in pH 4 calibration solution, enter 4, as shown in Figure 6-4.
2. Rinse the probe in clean water and place it in the second calibration solution. Repeat the measurement. In the example in Figure 6-4 the second solution is pH 7.

3. Click on **Next**.

Meter 1 Configuration Wizard (Type: Analog Monitor - Analog Input 1)

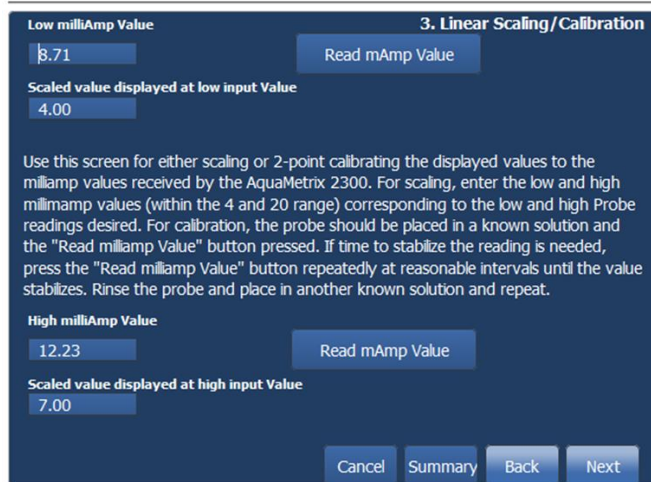

Figure 6-4 – Wizard window for linear (2-point) scaling.

6.2.5. Example: Calibrating a pH probe

For a more detailed description of calibrating a probe let's use a pH probe as an example. A pH calibration is almost always a two-point exercise. The two points used for calibration are from two of three pH calibration standards: pH 4, 7 and 10. If one's process is on the acid side one chooses pH 4 and 7 for the points. If the process is on the basic side then one chooses pH 7 and 10.

Figure 6-4 shows a pH calibration using standards pH 4 and 7. The procedure is simple:

1. Rinse the probe in water (tap water is just fine) and immerse it in the pH 4 buffer. In the field, "**Selected value displayed at low Input Value**, enter 4.00.
2. Swirl the probe around for approximately 20 seconds and click on the **Read mAmp Value** button. Read the **Low milliamp Value**. For pH 4 it will be approximately 8.5 mA.
3. Click on the button after an additional several seconds to gauge whether or not the probe output is still changing or has settled down.
4. When you are confident that the probe output is stable—typically in about one minute—take the probe out and rinse it in water. The last reading taken is the final mA value associated with the pH 4 calibration point.
5. Immerse the probe in the pH 10 buffer and repeat steps 2 through 4. This establishes the mA value for pH 10.

You have now mapped pH output currents to the corresponding pH calibration values. You can calibrate the probe at 3 or even more pH points but that is rarely necessary. Alternatively, if only one pH buffer is available or you wish to standardize your probe output to match a predetermined output value, you can "pin" the second value to a reasonable output value. Table 4 lists the ideal mA output values for the 3 pH buffer standards as well as pH values of 0 and 14. So, for example, if you

can only calibrate with pH 4 buffer you can manually set the second buffer to 7 or 10 using the values in the table.

Table 4 - Ideal mA output values corresponding to standard pH values

pH	0	4	7	10	14
mA	4.00	8.57	12.00	15.43	20.00

6.2.6. Scaling of a Transmitter signal

If the analog signal is from a transmitter instead of a probe then this operation is a true scaling exercise. The procedure is similar to that of a true calibration. The difference is that the probe is connected to a transmitter instead of the 2300. The transmitter 's 4-20 mA output connects to one of the 2300's four analog inputs.

1. Place the probe in the first calibration solution. Allow time for the probe value to settle down and click on the **Read mAmp Value**. Just as before enter the calibration solution value into the **Scaled value...** field.
2. Repeat for the second calibration solution.
3. Click on **Next**.

6.2.7. Non-Linear Scaling

Non-linear scaling is a calibration or scaling of between 2 and 32 points. The term "non-linear" is a bit misleading. That scaling may be (in theory) linear, as in the case of a pH sensor for which one wishes to calibrate the sensor in the three common calibration standards of 4, 7 and 10. Or it may be truly non-linear. Figure 6-5 shows the non-linear 4-20 mA output from a temperature sensor.

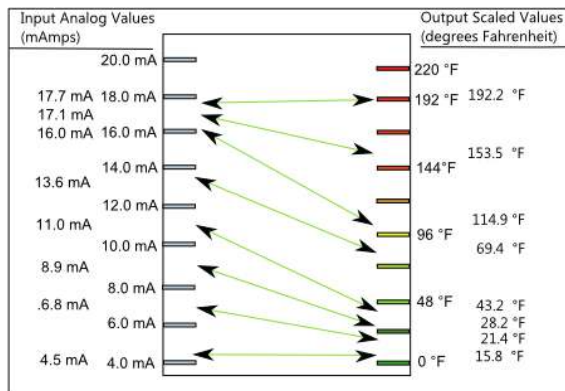

Figure 6-5 - Example of non-linear scaling. The 4-20 mA output of a temperature sensor is non-linear with temperature.

To construct a non-linear scaling/calibration curve:

1. Choose **Non-Linear (up to 32 points)** in the Probe Information window (Figure 6-3).

- There is no provision for automatically inputting the 4-20 mA value into the calibration as in the linear scaling routine. One must enter each pair of calibration points (mA output, calibration value) into the text box shown in Figure 6-6.

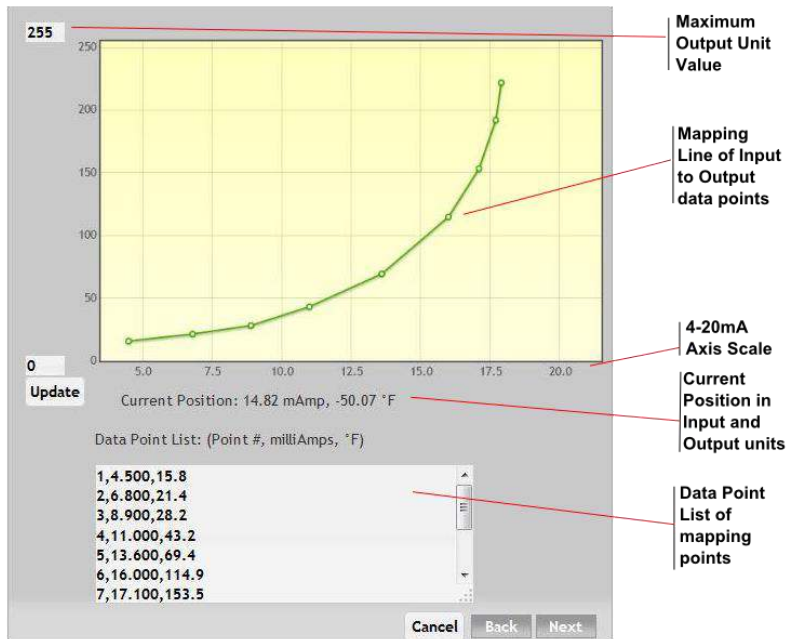

Figure 6-6 - Non-linear scaling window. One must enter the calibration points manually into the bottom text box. This example shows a true non-linear scaling though this “non-linear” scaling can also be done for a linear output sensor.

- Alternatively you may move your mouse cursor over the point in the where your calibration point ought to be and click on that point. The cursor point appears in the text box and you can edit that point.
- To obtain mA output values during calibration you can use the Linear Scaling screen as an ammeter.
- Click **Next** when done.

The power of the scaling/calibration wizard is that one can manually enter or edit calibration data manually, i.e. one does not have to take live measurements.

6.2.8. Scale Factors

This is a rarely used scaling method. The scale factor option just multiplies the scale factor entered by the input. This may be used to change units, or in the virtual probe configurations, to customize the output readings.

6.2.9. Probe Details

The next window allows you to specify the display of digits and the unit of measure. When you click on the **No Units** button a drop-down list allows you to choose from a number of pre-set units. If the unit you want is not included then click on the **[Enter New Unit]** choice at the top of the list and create your own unit.

To delete or add units of measure, go to **Setup > System Configuration > Unit List**.

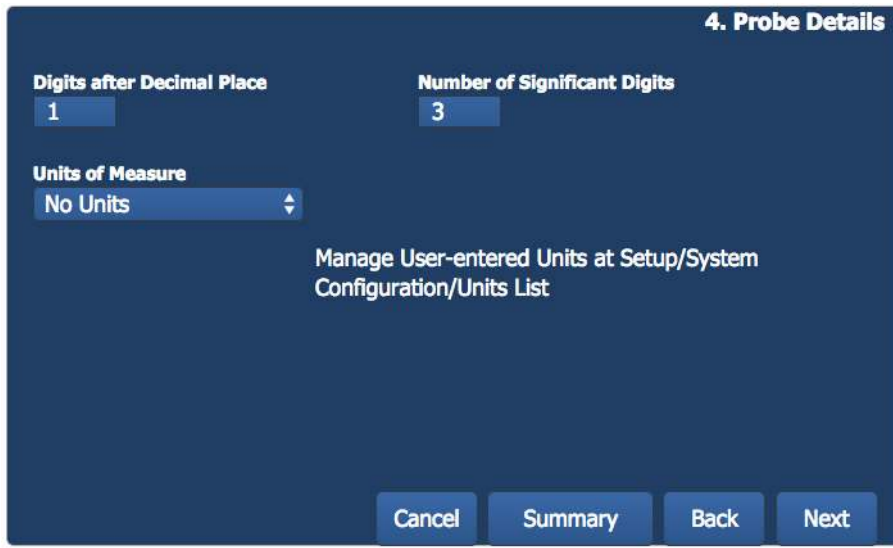

Figure 6-7 - Probe Detail window.

6.2.10. Probe Description

The Probe Description screen serves as a notepad where you can enter any descriptive text you wish about the sensor and its environment. Information such as the make and model of the probe, the process and the location of the probe can all be entered here. In the case shown in Figure 6-8 the information about the conductivity sensor informs the user that it is an ES-5-2 and it is located in the bottom of the sump.

The probe description text is repeated in the web interface: Click on the **Config** button in any of the Probe Status windows to change the scaling of the y-axis and to show the probe description.

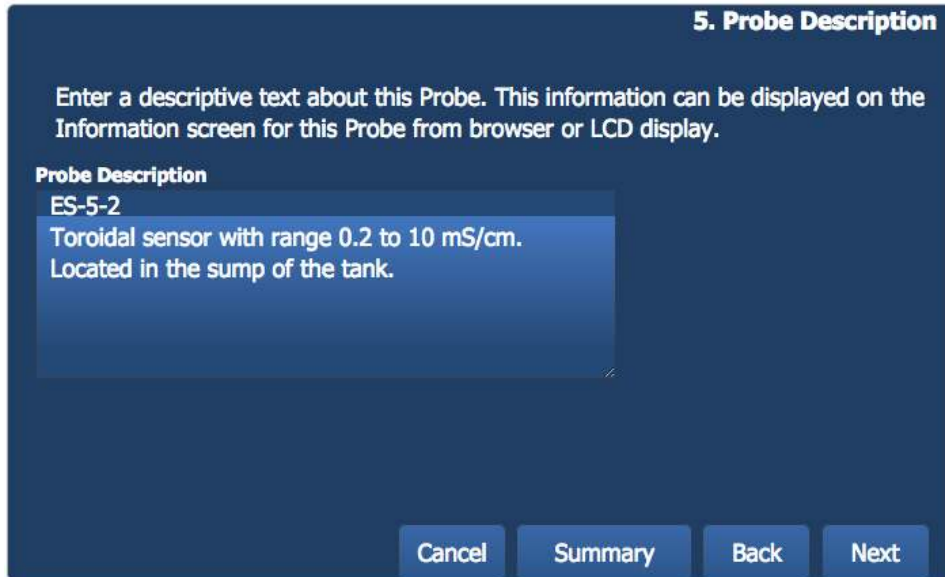

Figure 6-8 – This dialog box allows you to enter any information that might be of use to the user. In this case the probe model is the ES-5-2 and the probe is located in the sump.

6.2.11. First Action Configuration

Each probe can be configured to provide multiple alarms, relay activations, and email notifications. The 2300 is designed to allow full flexibility of assigning any or all of these outputs to any or all of the probes, including virtual probes. You are limited only by the number of hardwired relays on your controller, four of which are standard but more of which may be added using an optional card.

The word “action” is used to describe an alarm or a relay. The multiple ways in which alarms and relays can be combined adds power and flexibility to the 2300. Figure 6-9 shows the **First Action Configuration** window.

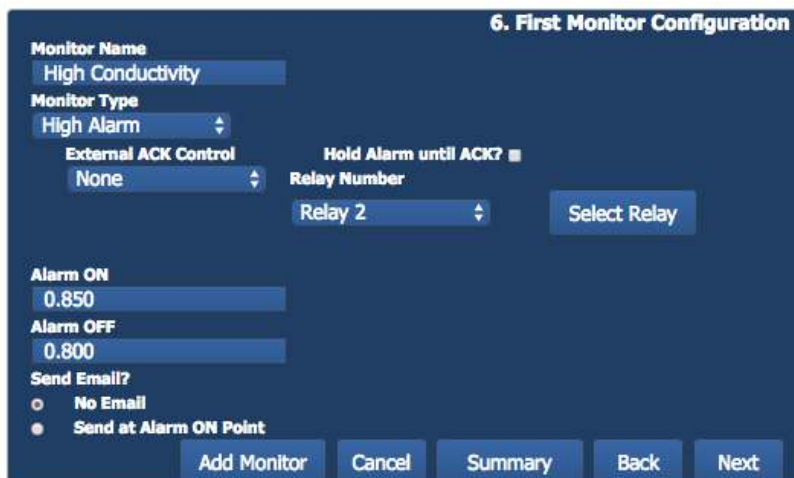

Figure 6-9 - Action Configuration Wizard

6.2.12. Action Name

The first field is simply a name of the action that you create. In the example shown in Figure 6-9, the action for the conductivity sensor is named “High Conductivity” for obvious reasons.

6.2.13. Action Type

Table 5 summarizes the possible action types. There are two types of actions: controls and alarms. Both actions enable relays. To decide which action option to use, follow this simple guideline:

1. To set a relay that is normally open (NO), i.e. closes upon activation, choose one of the **Alarm** options and select a **Relay Number**.
2. To set a relay that is normally closed (NC), i.e. opens upon activation, choose one of the **Control** options. Note: Only firmware version 1.7.3 or later allows you to change the status of a relay from NO to NC.

Table 5 summarizes the options for all action options.

Table 5 – Possible Action types and their properties

Action	Type	Trigger	Rules
Fill Control	Relay	Falling process	Trip point
Empty Control	Relay	Rising process	Trip point
Low Control	Relay	Falling process	Trip pt < Reset pt
High Control	Relay	Rising process	Trip pt > Reset pt
Low Alarm	Alarm	Falling process	Trip pt < Reset pt
High Alarm	Alarm	Rising process	Trip pt > Reset point
In Range Alarm	Alarm	Within range	Low trip pt < Low reset pt High trip pt > High reset pt
Our of Range Alarm	Alarm	Out of range	Low trip pt > Low reset pt High trip pt < High trip pt

The **Fill Control** and **Empty Control** types are tailored toward flow sensors used in dispensing applications and unlikely to be used with an analog sensor. It is unlikely that one would ever set a relay for an **In Range Alarm** and **Out of Range Alarm**. For most cases of process control, relays operate in NO state, so that an alarm is chosen first and the alarm attached. All relays require a hysteresis or dead band setting. This simply means that the process value that activates a relay is different from the value that deactivates the relay. The following rule applies.

1. For a **falling** process the trip point must be **lower** than the reset point.
2. For a **rising** process the trip point must be **higher** than the reset point.

You can specify as many emails or text notifications as you wish.

6.2.14. Acknowledging Alarms

Many users want to ensure that someone acknowledges an alarm that has been triggered. To ensure that this happens, click on the **Hold Alarm until ACK?** check box. There are two ways to acknowledge an alarm.

1. The **Acknowledge Alarm** option affects the behavior of the front panel Detail window. When the process triggers an alarm the Detail screen appears with a flash red bar around the trigger process value. When the check box is activated you must click on the **Enter** button on the front panel to acknowledge the alarm. The display then changes to the Meter Actions screen shown on the right side of Figure 6-10. Click on **Enter** in this new screen and the screen on the left of the figure returns—only this time with a steady red rectangle around the **High Alarm** row. To switch to the four-up screen press the **Run** button.



Figure 6-10 - The bar around the High Alarm alert flashes red until you press the **Enter** button. Pressing the **Enter** button on the Meter Actions screen brings you back to the screen on the left—only this time with a steady red bar.

2. The External ACK Control dropdown menu allows the user to acknowledge an alarm through a switch. Any available pulse input can be used as contact inputs.



Figure 6-11 - The first 2300 version, shown on left, has two sets of contacts connecting a switch to reset the totalizer on a separate connector (C1-C4). The most recent version has no separate connector for a switch. However, any two connectors on the pulse (or "digital") connector can be used as an input for a switch.

6.2.15. Selecting a Relay

The relay connector on the back of the 2300 consists of 4 pairs of terminals. An optional card allows the use of an additional 4 pairs. Each pair is a NO (normally open) switch. There is no NC (normally close) input. The choice of configuring the relay as NO (normally open) or NC (normally closed) is done in software. **You can configure a relay for multiple probes.**

There are two ways to select a relay:

1. Figure 6-9 shows the button, **Relay Number**, which accesses a pull-down menu of relays. You can click on any relay to select it.
2. You can click on the **Select Relay** button to bring up a photo of the terminals. Figure 6-12 shows a photo of the connector containing all four pairs of terminals. When the relays are all unused picture of the relays will show yellow rectangles surrounding each pair of terminals. If another probe or relay setting has already utilized a relay that that relay will appear as a shaded blue rectangle over the pair of terminals. When your cursor is over that shaded rectangle a description of the relay's function will appear as in Relay 1 shown in Figure 6-12.



Figure 6-12 - Relay connections on the back of the 2300. The yellow rectangles show relays that are unused. The shaded blue rectangle over Relay 1 shows a relay that is configured for a previous sensor and a text box lists the relay function. You can still select that relay for another probe.

6.2.16. Emailing Alarms and Controls

The radio buttons on the bottom of the First Action Configuration enable the 2300's web server to email (or text) an alarm or relay trip to the addresses. Clicking on the button to enable send an email alert brings up another screen, titled Email Send Configuration. There is a drop down menu for **Subject** that contains messages already configured in the Email setup (Section 5.6.4.4). You can create a new subject and message and that choice will be added to the library of email subjects in the **Email List Configuration** (Network Setup > Email Setup > Email Message Setup).

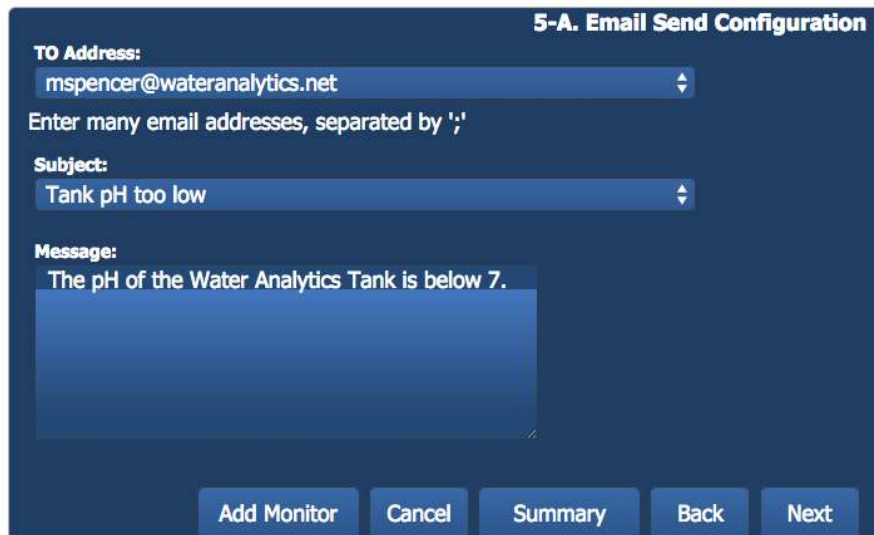

Figure 6-13 –This screen appears when you enable email notification of alarms and controls. You may choose from amongst previously configured Subjects and Messages or compose a new one.

6.2.17. Adding Additional Actions

To configure additional relays or alarms click on the **Add Action** button on the bottom of the Add First Action screen. Repeat the same process. You can attach as many as three actions to any one process.

6.3. Connecting a Pulse Output (Flow) Sensor

Pulse output sensors output a square wave whose frequency is proportional to the process variable. They are also known as **digital** sensors, though that name can be misleading since they do not deliver information in the form of digital data. The overwhelming majority of these sensors are paddle wheel and magnetic induction flow meters. The controller measures the pulse frequency and uses a constant of proportionality, called the **K-factor**, to convert the frequency to a flow value. The K-factor obviously is specific for the time and volume units. However scaling the K-factor to a different time and/or volume unit is as simple as scaling the new unit to the old unit.

Many of the steps outlines in Section 6 apply to the pulse output sensor so this section need only list the steps that differ from the setup of analog probes.

6.3.1. Probe Selection

Refer to Section 6.2 for details of the steps already described for configuring an analog sensor.

Navigate to **Setup > Probe Configuration**. Find an empty channel and click on the **Click here to add new Probe**. The Probe Configuration Wizard begins.

In the Probe Selection screen, select **Precision Pulse Probe** or **Pulse Input Probe**. Section 6.1 summarizes the difference between the two. Precision pulse probes are more accurate so it makes sense to fill the two precision pulse sensors (Dig in 1 and Dig in 2) before connecting a flow sensor to the single pulse input probe connector (Dig in 3). Clicking on the **Select Input** button brings up a picture of the back of the 2300 with a red rectangle surrounding the unused pulse probe (Dig in) connectors. In Figure 6-14 Precision Pulse Input #1 has been chosen. The photo of the back that Select Input bring up shows the location of that connector—labeled as **Dig in 1**. Click on **Submit** to lock in the choice of input.



Figure 6-14 – The New Probe Wizard screen allows the user to choose either of the two **Precision Pulse Inputs** or the single **Pulse input**. The right hand photo shows the red rectangle.

6.3.2. Probe Information

In the Probe Information screen, one enters the **Probe Name** as described in Section 6.2.2. For Scaling/Calibration the only choice is **K-Factor**.



Figure 6-15 - The only choice for Scaling Type/Calibration for a pulse input probe is K-Factor.

6.3.3. K-Factor Scaling/Calibration

Scaling or calibrating a flow sensor generally does not require the use of calibration standards. Typically calibration has already been done at the sensor's manufacturer. The scaling factor is the K-factor, which one enters in the next screen.

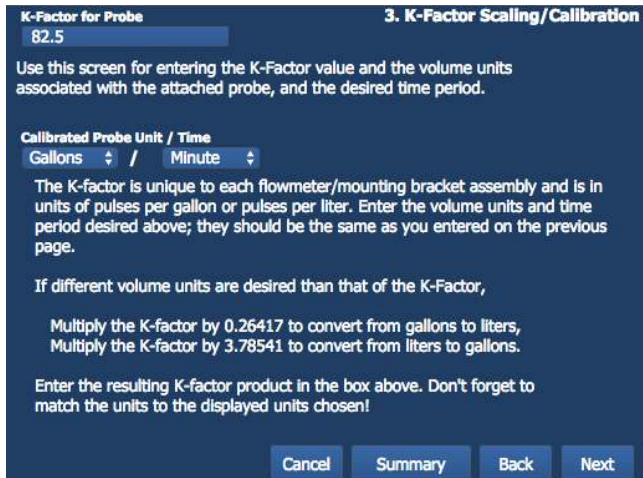

Figure 6-16 - The K-factor is supplied by the manufacturer and is specific for the volume and time units. Those units must be entered in this screen so that the 2300 calculates flow in the correct units.

Figure 6-16 shows the screen in which one enters the factory-supplied K-factor. In order for the 2300 to calculate flow in the correct units you must also enter the units of volume and time. In the example in the figure those units are gallons and minutes. To calculate flow in other units, say liters/min, only needs to multiply the K-factor by the same constant that converts the old units to the new units.

6.3.4. Probe Details

In the **Probe Details** screen, the **Units of Measure** have to be consistent with the units for the K-factor.

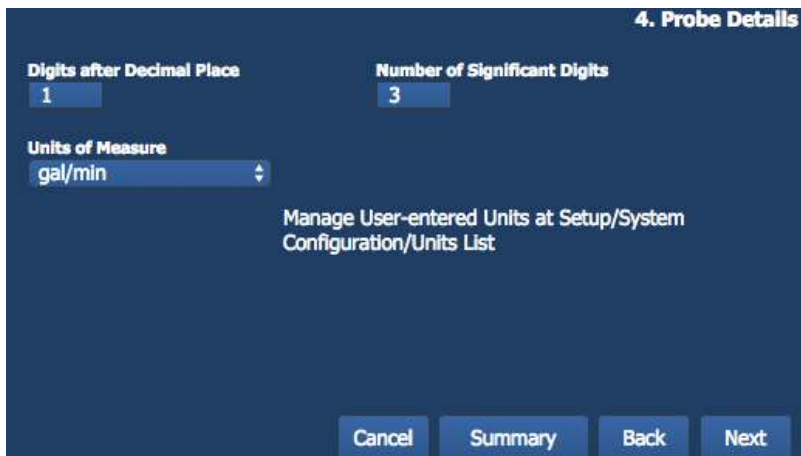

Figure 6-17 - The units in the Probe Details screen must match those of the K-factor.

6.3.5. Probe Description

As for analog probes, this screen allows you to write any description of the probe and its environment. We suggest writing the probe model and its location.

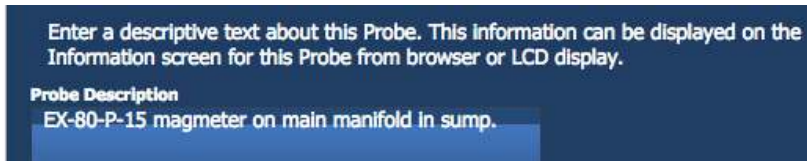

Figure 6-18 - The Probe Description in this case lists the model and the location of the flow sensor.

6.3.6. Action Configuration

The setup of alarms and relays is identical to the instructions in Section 6.2.11.

6.4. Connecting Virtual Probes

One of the most powerful features of the 2300 is its ability to construct “virtual” sensors from real ones. The most common type of virtual sensor is the totalizer, which integrates the flow over time to calculate a total volume. Totalizers are integral to batch control of dispensing liquids into containers. Other examples include a differential pressure sensor.

6.4.1. Configuring a Totalizer Probe

The Totalizer Sensor counts the number of cycles or pulses on one of the digital inputs. It may be used to action the amount of time a piece of equipment is operating or totaling a flow to action the volume of fluid over a period of time. The Totalizer can be used to trigger an alarm, alert, or relay when a volume or total has been exceeded, or every time a pre-set periodic count is reached (e.g. if set to 100, will alarm at 100, 200, 300, etc.). The Totalizer may be based on an input previously configured, such as flow, or be used to configure the input itself. The former method allows both the flow and totalizer to be displayed and activated by their own alarms and relays. The following instructions are for this mode of operation.

1. Navigate to **Setup > Probe Configuration**. Find an empty channel and click on the **Click here to add new Probe**. The Probe Configuration Wizard begins.
2. In the Probe Selection screen select **Totalizer Probe** from the Probe Type drop-down menu. Please note that the easiest way to configure a flow totalizer is to first configure a flow meter and then select configured flow sensor from the drop-down menu. Configured sensors appears below the dashed line.

If you select the “raw” Digital Input as a source for the totalizer – it will count raw pulses and not the flow data. Clicking on “Select Input” button will only show raw “Digital Inputs”, don’t use that button if you are setting a flow totalizer from a configured flow meter.

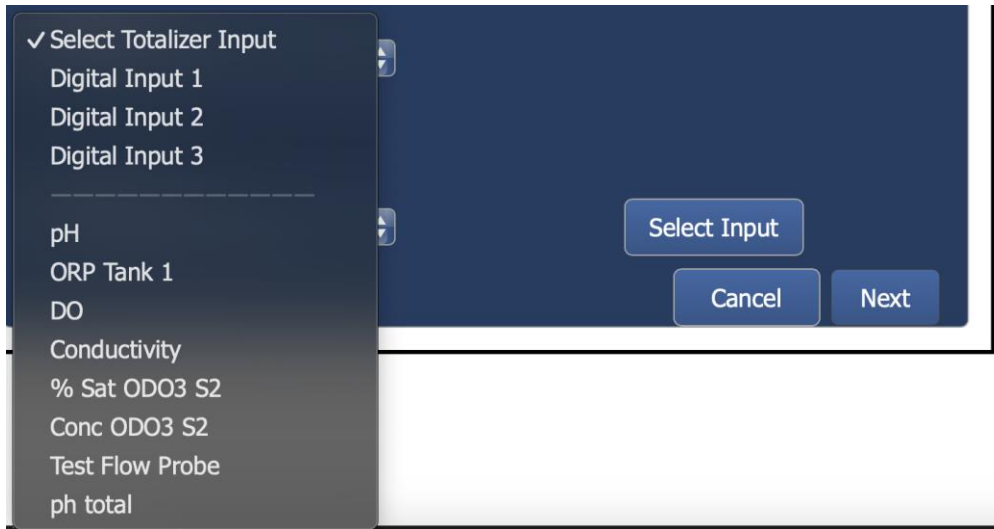

Figure 6-19 - The totalizer probe takes its real input from a flow sensor, which, is Test Flow Probe in this example. Click on **Next** when the correct Flow Meter is selected.

3. After an **Instructions** page the **Totalizer Information** page opens. Enter the name of the totalizer in the **Enter Totalizer Name field**.
4. Scaling may be required for the totalizer to work correctly. Since the totalizer adds a value every second, you want to make sure that flow units have seconds in denominator (i.e. liter/sec, or gallons/second). In case flow units were configured as GPM (gallons/minute) you need to use scale factor of 60.0 to convert them to gallons/sec.
5. Every totalizer needs to be zeroed at any time. This can be done any of the three ways:
 - a. Using the front panel or on the web-interface.
 - b. The **External Zero Control** offers the capability of zeroing the totalizer from an external switch. The switch is a simple SPST that connects to one of the inputs of the pulse (digital) inputs.
 - c. Automatically reset at midnight (configured in the totalizer setup)
6. To reset the totalizer from the web interface click on the **Config** button to top right of the graph and then click on **Reset Totalizer**. To reset the totalizer from the front panel, click on the **→** button to get to the detailed screens, then click on **Enter** to reveal the **reset** option.)
7. The field, **Scaling Type**, enables one to switch from one set of units in the flow sensor to a different set. One simply enters the proportionality constant between the two units. For instance, if the K-factor for the flow probe is gal/min and you wish to read the total in liters then the scale factor is 3.785. Select **Scale Factor** from the **Scaling Type** menu. You will enter the conversion factor in the next page.

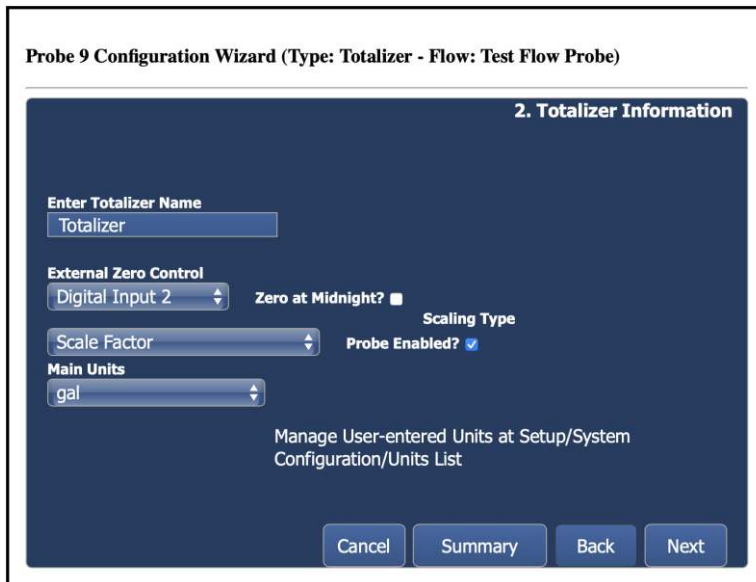

Figure 6-20 - Page for setting up an external switch to reset the totalizer.

8. You will normally want to check **Probe Enabled** to activate the probe.
9. If the totalizer keeps the same volume unit as the flow probe then enter that unit in the Main Units field. If you are switching units then enter the new volume unit. In the example mentioned above you would enter **galons** as the main unit. Click on **Next**.
10. If you selected **Scale Factor** for the **Scaling Type** then a small window appears asking you to define the scale factor. For the example above, the scale factor is 60 (GPM to gallon/sec).
11. The **Probe Description** allows you to write a description for the probe. As always, it is good practice to list the model of the probe and its location.



Figure 6-21 - The description for the totalizer is consistent with that for the flow probe to which the totalizer is connected.

The Action Configuration page works just as with analog probes. The Action sends an alarm or activates a relay when a volume total has been reached. Three types of action functions are supported: **High Alarm**, **High Control**, and **Periodic Counter Alarm**. The **Period Counter Alarm** will go off each time a multiple of the set total is reached if the Totalizer is set up with a K-factor or linear scaling. Use of the non-linear scaling feature allows for more complex functions of this **Periodic Counter Alarm**.

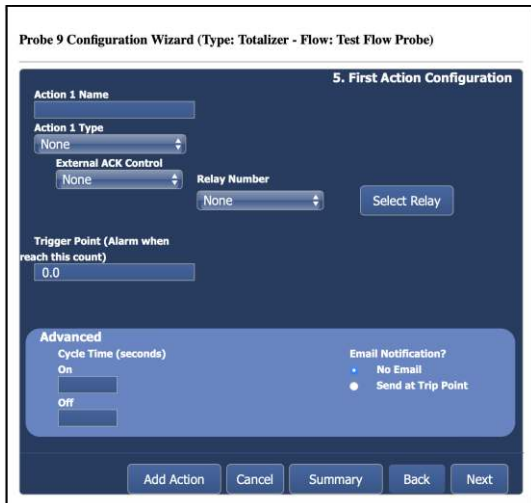

Figure 6-22 - Action Configuration for a totalizer probe attached to a flow probe.

6.4.2. Configuring Differential Sensors

A **Differential Sensor** combines two existing analog or digital probes and performs a subtraction operation between them, displaying the resulting differential value as a separate, virtual, probe. Thus, there are 3 readings on the controller for two actual probe inputs. A typical application would be to measure the difference of flow before and after a valve, a pressure differential or a difference in temperature.

There are few differences between setting up a virtual differential probe and a real analog or digital probe. The Probe Selection page asks you to choose the two real probes from the drop-down list of existing probes.



Figure 6-23 - Section of the Probe Selection page showing the definition of the differential sensor.

The differential sensor may be scaled after the subtraction and units assigned to the resulting value just like another probe. Similarly, controls and alarms may also be assigned to the differential value. Be aware that the difference value is already scaled from the input current values, so that further scaling is liable to provide non-meaningful values. The difference value may be either positive or negative.

The differential sensor may be edited but the original two inputs it is based on are fixed in its definition. To change one or both inputs, delete the differential sensor in the main Probe Configuration menu and define a new one. Keep in mind that the units of the differential sensors must be the same as the units of the source probes.

6.4.3. Configuring Virtual sensor using Formula

The **Formula** options allow the AM-2300 Controller to create common mathematical action between configured sensors. This can be used to display difference between two probes, sum, or ratio.

As these specialized virtual probes are refined this manual will be likewise revised. Check our website for the latest version.

7. Appendix

7.1. Optional I/O Card Types

7.1.1. 4-channel Analog Input Card

This is the most often ordered optional card and allows an additional 4 analog inputs to be added to the existing 4 inputs for a total of 8 analog inputs.

7.1.2. 3-channel Digital Input + 4-channel Digital Relay Output card

The 3-channel Digital Input + 4-channel Relay Output card is included with the 2300 standard model. A second card brings to 6 the number of digital inputs and to 8 the number of normally open relay outputs. The additional relays and digital inputs will appear in the drop down menus as numbers 5-8 and 4-6, respectively. In addition, they can be used as an external **Acknowledge** input for an Alarm.

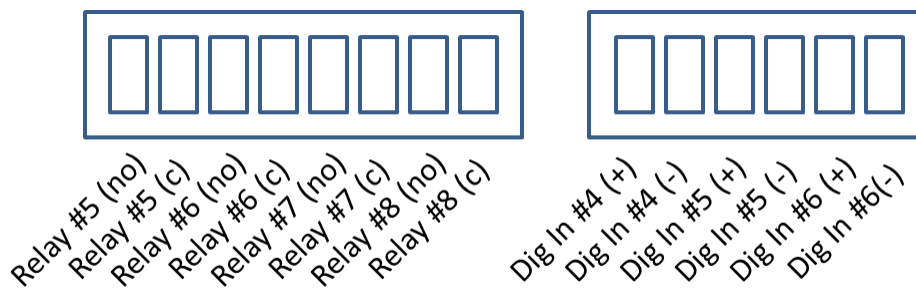

Figure 7-1 - 3 Input + 4 Relay Output Card connections

7.1.3. 6-channel Relay Output card

The 6-channel Relay Output card provides four normally open relay outputs and two relay outputs that have both normally open and normally closed contacts with the following connections:

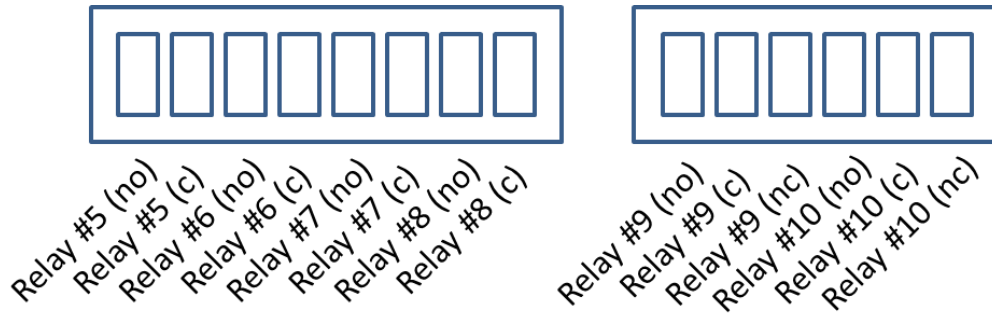

Figure 7-2 - 6 Relay Output Card connections

7.1.4. 7-channel Digital Input card

The 7-channel Digital Input card provides seven additional digital inputs with the following connections:

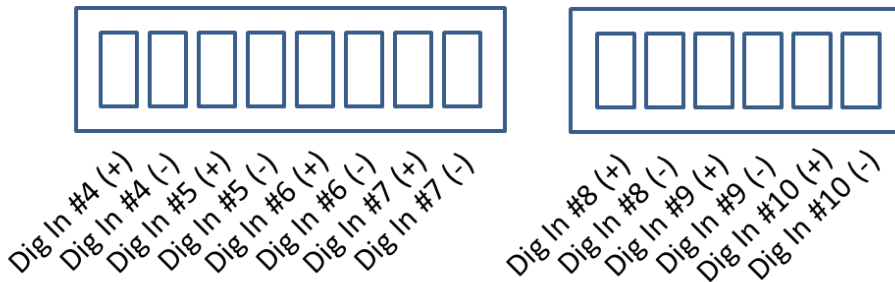

Figure 7-3 - Input Card connections

7.1.5. 4-channel Analog Output card

This card provides for 4 channels of 4-20 mA output loops, which may be programmed via the Action function in the Probe Configuration Wizard. More than one output may be set for an input, and the outputs may be used for the virtual channels as well.

When the analog output card is inserted the 2300 will automatically recognize it. When the user connects a new analog probe and clicks on the Select Input button the back of the 2300 showing the Analog Output connector appears, as shown in Figure 7-4.



Figure 7-4 - During set-up of an analog probe to a 2300 with an analog output card, the analog output connector (on top) appears.

Control of the analog output signal is through the action type, **Analog Output**. As Figure 7-5 shows, this action type only shows when the analog output card is installed. There are two options for configuring the 4-20 mA output:

1. The 4-20 mA output mirrors the 4-20 mA input.

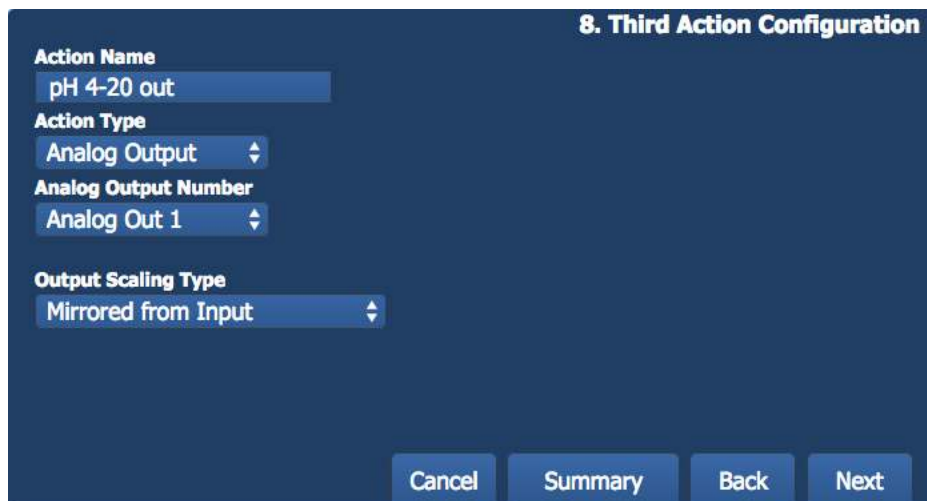

Figure 7-5 – With the analog output card installed

- The 4-20 mA output is scaled so that the process value maps linearly into any range of 4-20 mA output. Figure 7-6 shows the example of a pH probe for which a pH value of 4.0 outputs a current of 4 mA and a pH value of 10 outputs a current of 20 mA. This scaling is useful for expanding a limited range in process values to fit the entire 4-20 mA range.

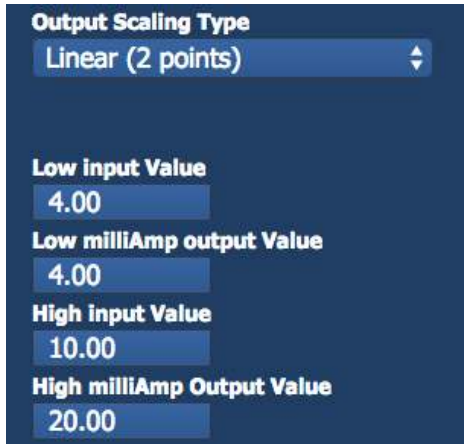

Figure 7-6 – In this example for linear (2 points) scaling a pH probe value of pH 4 outputs 4 mA and pH 10 outputs 20 mA.

The Probe Status screen now displays the 4-20 mA output value. Figure 7-7 shows an example of a pH probe that measures a pH of 5.5 outputs 8.00 mA.

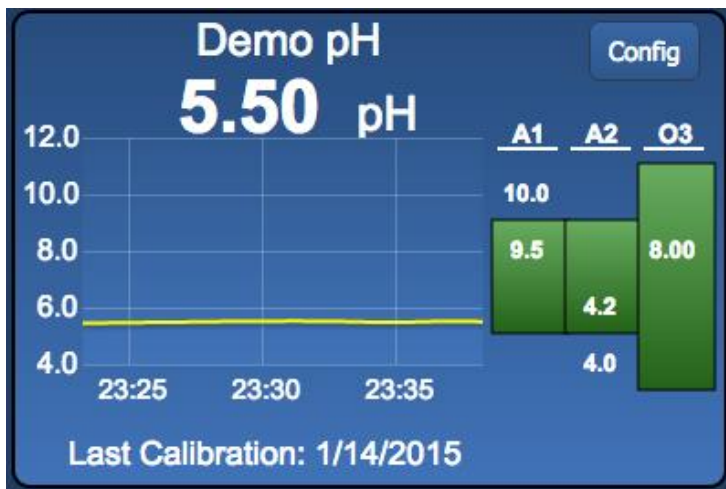

Figure 7-7 - The Probe Status screen shows the analog output in the 3rd bar.

7.2. Email Keyword List

Email keywords allow you to customize email alerts so that they tell the receiver precisely what happened in your process.

Keyword Name	Email Keyword	Description
System Name	{{#systemname}}	Name of the AquaMetrix 2300 sensor that sent the email message
System Time	{{#systemtime}}	Time that the email message was sent
Sensor Name	{{#sensorname}}	Name of the Sensor that triggered the Alarm
System IP Address	{{#systemip}}	IP address of the AquaMetrix 2300 sensor that generated the Alarm
Description	{{#mdescrip}}	Description that was entered during the configuration of the Sensor
Alarm Value	{{#alarmvalue}}	Scaled value of the probe when the alarm was generated
Alarm Limit Value	{{#alarmlimitvalue}}	Trip point of alarm that was generated
Alarm Compare Verb	{{#alarmcompareverb}}	"Above" if high alarm/relay. "Below" if low alarm/relay.
Action Name	{{#relayname}}	Name of the Action (relay or control) that was triggered
Alarm Name	{{#alarmname}}	Type of alarm (e.g. high alarm)
Sensor Value	{{#currentvalue}}	Current scaled value of the Sensor at the time the email message was sent
Control State	{{#relayresult}}	ON or OFF state of the output relay at the time the email message was sent

7.3. Panel Mounting

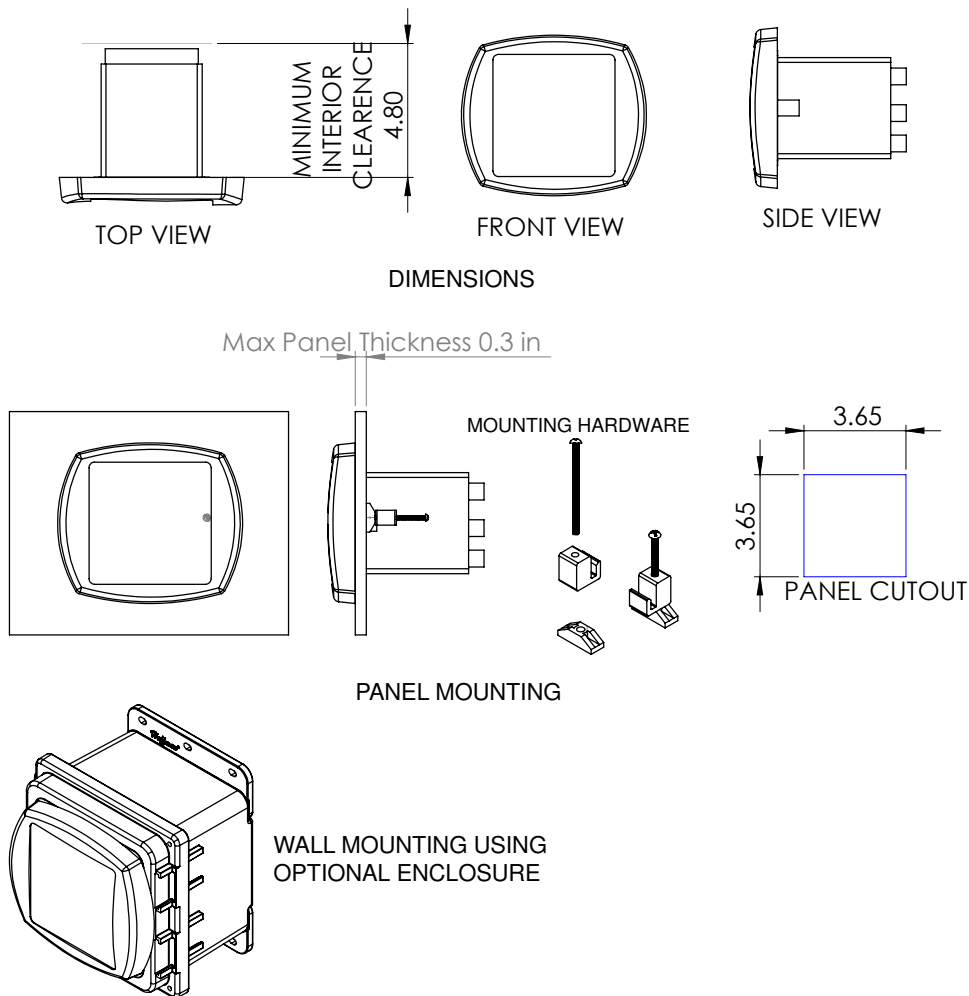

8. Get the Latest Firmware

Because the 2300 is so ground-breaking we are always working to improve the user interface with cool new features and easier to use old ones.

To ensure that you receive the latest firmware update please check our website:

www.wateranalytics.net

After setting up the probes and the actions, the network connection may be severed if desired, allowing the AM-2300 to be used as a stand-alone controller. Keep in mind, however, that email/text notifications and changes to the 2300's configuration require a network or computer connection.

Training videos are available from our website at www.Aquametrix.com.

We hope you have fun with this new controller, but if you have problems, feel free to call us at (978) 749-9949.