



## Description

The new and improved one inch sensor is the latest additions to the legendary AquaMetrix differential probe family. The 1" version is now comes in distinctive blue PPS (Ryton®) for superior resistance to chemical and mechanical weathering.

The replaceable salt bridge has been completely redesigned for this series - no special tools required! Simply grab a #3 Phillips screwdriver or 1/2" wrench and rejuvenate your sensor in seconds.

The improved, universal flat-faced glass process electrode is specially designed for tough applications. A larger surface area guarantees quick readings and outstanding performance, and a self-cleaning flush fit when installed inline ensures upkeep will be minimal. The process electrode is now encased in a protective layer of PPS offering increased resistance to physical damage compared to previous versions.

All of our 60-series sensors are dependable industrial grade sensors designed to provide accurate measurement and longer service life under the most demanding conditions. The new R5-series incorporates all the benefits of differential measurement found in other models of the 60 series, field proven in thousands of installations.

Differential measurement technology uses two glass electrodes to make the measurement differentially with respect to a third metal electrode. The resulting true differential measurement has several advantages over conventional sensors: ground loop problems are virtually eliminated and the probe can be restored to factory condition at modest cost by replacing the salt bridge and reference solution.

Automatic temperature compensation is accomplished through the use of a thermistor at the tip of the probe. This thermistor placement provides rapid response for process temperature variations.

The new version of this sensor is compatible with any off-the-shelf 1" NPT fittings, and serves as a drop-in replacement in fittings designed for the previous iteration.

The encapsulated preamplifier in 60-series provides an output signal which can be transmitted 2,000 feet over inexpensive cable. Our 65-series of this sensor encapsulates a blind 4-20 mA two wire transmitter which can transmit a virtually unlimited distance over a twisted pair cable (see P65R5 datasheet).

## Features

- Low cost of ownership
- Replaceable Salt Bridge
- Flat face electrode is standard
- Encapsulated preamplifier transmit up to 2,000 ft
- Chemically resistant PPS body
- Universal style: flow-through and submersion
- Temperature output
- 24 hour quick ship available

## Applications

- Process Control
- Industrial and Municipal Waste Treatment and Neutralization
- Fume Scrubbers
- Plating
- Circuit Board Manufacturing
- Mining
- Power Generation
- Food and Beverage
- Aquaculture
- Agriculture

# AquaMetrix P60R5 pH Differential Sensor

## Technical Data

Linear Measurement Range	1 to 12 pH Response at pH<1 or >12 is non-linear (<59.2 mV/pH @ 25 °C)
Wetted Materials	Ryton® (PPS), Ceramic, Glass, Viton®, Titanium, *PVC (cable jacket), Santoprene® 101-55 (strain relief; when fully submerged)
Temperature Limits	-5 to 75°C (23 to 167°F)
Maximum Pressure	100 psig at 150°F (65°C)
Maximum Flow Rate	10 ft./sec maximum (3 meters/sec) but lower in water with low conductivity water or suspended solids
Automatic Temperature Compensation	Standard PT1000Ω RTD; Optional: 300 NTC
Stability	0.03 pH per day, non-cumulative
Sensitivity	0.01 pH
Accuracy	± 0.02 pH
Sensor Cable	Default Length 15ft (4.6m) 5-wire with shield

## Dimensions

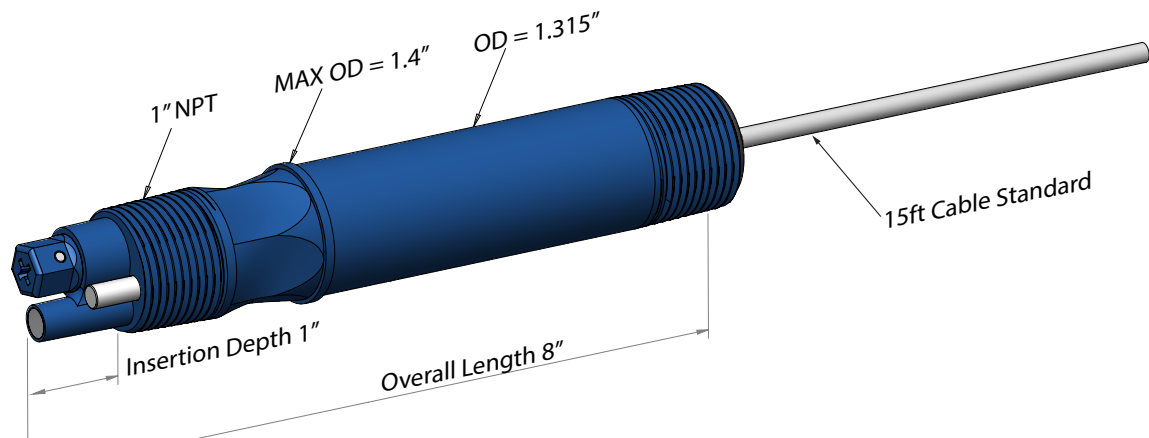

## Related Products

### ANALYZERS

AM-2250	Multi-Parameter Controller
AM-2250TX	Multi-Parameter Transmitter
AM-2252	Dual Input Multi-Parameter Controller

### ACCESORIES

AM-SBK3-R5	Salt bridge kit (3 pack) for R5 sensor
AM-SBK10-R5	Salt bridge kit (10 pack) for R5 sensor
AM-CFT-R5	1.5" compression fitting for R5 sensor
AM-TEE-5	2" Union TEE with adapter
AM-ARM-5	Submersion Arm
AM-PTR-5	Electrode Protector
AM-JET-5	Jet Cleaner
AM-SFL-5	2" Sanitary Flange
AM-JB2	NEMA 4X Junciton Box
AM-CBL	Universal extention cable

## Ordering Information

P60R5-015	Raw output industrial differential pH sensor for flow-through or submersion application. Compatible with 2250-series and all legacy Shark AquaMetrix analyzers. Standard 15 ft cable.
P60R5N-015	1" differential pH sensor with 300NTC thermistor. Compatible with legacy AquaMetrix analyzers.

### CALIBRATION SOLUTIONS

AM-PH4-1P	pH 4 Buffer, 1 pint (500 mL)
AM-PH7-1P	pH 7 Buffer, 1 pint (500 mL)
AM-PH10-1P	pH 10 Buffer, 1 pint (500 mL)