



## **AquaMetrix AM-PTX**

Differential pH Sensor with Analog and Digital Outputs



## **Installation and Operation Manual**

## Contents

1.	Introduction .....	4
2.	Safety .....	5
3.	AM-PTX Sensor and Specifications .....	5
3.1.	System Description.....	5
3.2.	Getting Started .....	5
3.3.	Specifications.....	7
3.4.	Dimensions .....	8
3.4.1.	PTXR5 .....	8
3.4.2.	PTXR5-M12.....	8
3.4.3.	PTXR8 .....	8
3.4.4.	PTXR8-M12.....	9
3.5.	Cable.....	9
3.5.1	PTXR5 and PTXR8 .....	9
3.5.2	PTXR5-M12 and PTXR8-M12.....	9
3.6.	Connections to Power Supply and Controller .....	10
4.	Installation .....	10
4.1.	Analog Connections.....	10
4.2.	Digital (RS485) Connections .....	11
5.	Digital Communication PC Configuration: .....	11
5.1.	Getting Started.....	11
5.2.	Port Configuration:.....	11
5.4.	Sensor Start up (over RS485) .....	12
6.	Calibration.....	12
6.1.	2 or 3 Point Calibration saved Direct to Sensor Using RS485 .....	13
6.2.	Calibration using AM-2300 Controller (4-20mA) .....	13
Front Panel.....	14	
Web Interface .....	16	
6.3.	Two-Point or Multi-Point Calibration with a Controller or PLC .....	17
7.	Maintenance.....	18
7.1.	Probe Cleaning .....	19

7.2.	Replacement of Salt Bridge .....	19
	<b>For R5 Series, Differential Probes</b> .....	19
	<b>For Series 8 Differential Probes</b> .....	19
7.3.	Storage .....	20
8.	Accessories/Replacement/Spare Parts.....	20
9.	Mounting .....	21
9.1.	Mounting Options for R8 sensors .....	21
9.1.1.	Submersion Mounting .....	21
9.1.2.	Flow-through mounting in a TEE .....	22
9.1.3.	Sanitary fitting for R8-series .....	22
9.2.	Mounting options for R5 sensors.....	23
9.2.1.	Submersion mounting.....	23
9.2.2.	Flow-through tee mounting R8-series Differential Sensors .....	24
9.2.3.	Sanitary fitting.....	24
9.2.4.	Variable insertion (R5-series only).....	25
9.2.5.	Hot Tap (Wet Tap) insertion mounting R5-series .....	25
10.	Troubleshooting.....	26
11.	Disposal.....	27
12.	Warranty .....	27
13.	Contact.....	27

## 1. Introduction

The new and improved PTX sensor is the latest addition to the legendary AquaMetrix differential sensor family. Our smart sensors maintain their robust design, but leverage the analytical power of our controllers, fully integrated. The 1" or 1.5" TX version also comes in a sleek Blue or Black, respectively, PPS (Ryton®) for superior resistance to chemical and mechanical weathering.

The advantages of digital output sensors are compelling. They include reduced noise, higher immunity from stray voltages, calibration stored in the sensor, and the elimination of intermediary transmitters. The PTX also comes with built in isolation, preventing ground loops, for the analog output communication which is important to keep your reading steady and accurate.

The new TX-series incorporates all the benefits of differential measurement found in other models of the 60 and 65 series, field-proven in thousands of installations.

The replaceable Salt bridge (CPVC for R8 and Ryton for R5) rejuvenates your sensor in seconds.

The improved, universal flat-faced glass process electrode is specially designed for tough applications and comes standard with the R5 design or an option for the R8. A larger surface area guarantees quick readings and outstanding performance, and a self-cleaning flush fit when installed inline ensures upkeep will be minimal. The process electrode is encased in a protective layer of PPS offering increased resistance to physical damage.

Aquametrix pH sensors are designed to simply and reliably ensure water quality compliance.

Aquametrix pH sensors provide accurate measurements under conditions that often render conventional pH sensors inoperable.

Differential measurement technology uses two glass electrodes to make the measurement differentially with respect to a third metal electrode. The resulting true differential measurement has several advantages over conventional sensors: ground loop problems are virtually eliminated and the sensor can be restored to factory condition at modest cost by replacing the salt bridge and reference solution.

The Automatic temperature compensation is improved through the use of a thermistor at the tip of the probe, providing rapid response for process temperature variations.

The sensor is compatible with our 1" or 1.5" NPT fittings and serves as a drop-in replacement in fittings designed for the previous iteration. You no longer need to sacrifice precision for longevity with AquaMetrix TX Sensors.

The M12 version of the sensor features IP67 connector that allows for easy sensor removal for service or calibration.

## 2. Safety



### **WARNING**

**Electrical hazard:** Do not install the probe unless you have electrical training and you have read the instruction manual. The probes and blind transmitter use a 24V power supply and improper installation and handling can result in injury or damage to surrounding equipment including this probe.



### **NOTICE**

**The probe should only be installed, stored and serviced in the manner described in this manual. Improper handling may result in damage to the unit and surrounding equipment and may void the warranty.**

## 3. AM-PTX Sensor and Specifications

### 3.1. System Description

This manual covers all AquaMetrix “Smart” TX Series differential measurement pH probes. The P-TX is a next-generation pH sensor built on the 50+ years of AquaMetrix’s legacy of building durable and easy-to-use sensors. The PTX can work with the AM-2300 controller, as well as most third-party PLC controllers. Contact AquaMetrix to confirm compatibility.

The PTX also has an RS485 connection that allows user to read and write to the sensor.

### 3.2. Getting Started

The P-TX sensor is factory calibrated and works out of the box. No additional programming is required.

- 3.2.1. The PTX Sensor should be completely immersed in the sample when taking measurements.
- 3.2.2. If the distance between the probe and the instrument is such that a direct connection is not possible, the probe cable should be routed to a junction box with a terminal strip (AquaMetrix Part No. AM-JB2). The box should be well sealed and away from corrosion danger. Be sure that you have sufficient slack cable to allow for probe removal for calibration and servicing.
- 3.2.3. Route the interconnect cable from the junction box to the instrument, preferably in metal conduit. Do not run the power cable or control cables in the same conduit with the probe interconnect cable.

3.2.4. Remove the protective plastic caps from the end of the probe before placing in service.

3.2.5. For best results probes should always be mounted vertically with electrodes down. If this is not possible, the probe must be at least 15° above horizontal.

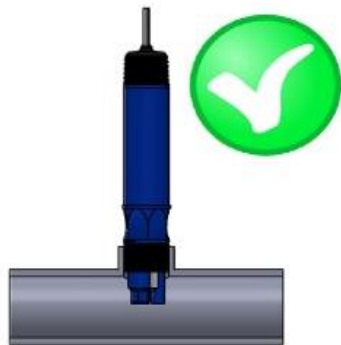

Vertical installation is recommended

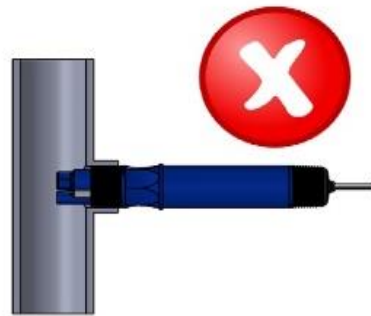

Horizontal or upside down installations are not acceptable

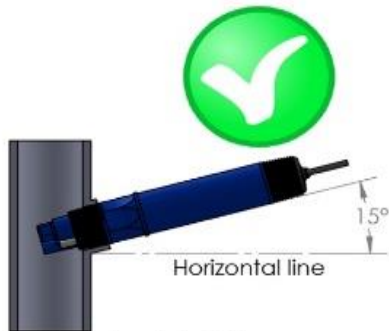

Vertical pipe installation



Horizontal pipe installation

Figure 1: General Mounting diagram

3.2.6. To optimize performance a site calibration is always beneficial, but not required.

### 3.3. Specifications

Probe Parameters	
Parameters	pH Sensor
Data Transmission	Analog (4-20mA): pH (Standard mapping is 0-14pH) Digital (RS485): pH, mV, Temperature
Range	1 to 12 pH Response at pH<1 or >12 is non-linear (<59.2 mV/pH @ 25 °C)
Accuracy Digital	+/- 0.03pH (1-12pH @ 25°C) +/- 1% Temp
Resolution Digital, pH	0.01 pH
Resolution Digital, mV	0.01 mV
Resolution Digital, Temp	0.1°C
Stability, Digital pH	0.03pH per day, non-cumulative
Resolution Analog	0.01mA
Response Time, pH	T90<30s T95<60s
Response Time, Temp	2min/°C
Units, pH	pH
Range, Temp.	0°C to 70°C (32°F to 158°F)
Units, Temp	Celsius, Fahrenheit
Temperature Compensation	Automatic via standard PT1000Ω RTD
Calibration	2-3 points via RS485 Connection OR 2- multipoint at local controller
Calibration Time	~1 min (for each point)
Physical	
Mounting	1inch (R5) or 1.5in (R8) threaded connection options
Flow Rate (max)	3 m/sec (10 ft/sec). Flow should be as low as possible in water with low conductivity water or suspended solids
Maximum Load	450 Ω
Pressure Limits	100 psig @ 65 °C,
Power Supply Limit	24±4 VDC,
Ingress Protection	IP68
Cleaning	Typical: Water and soft brush Biofilm: bleach soak ~20min Scaling: weak acid soak ~10min
Time between cleaning	(environment specific)
Wetted Materials	R8: Ryton®, CPVC, glass, ceramic, titanium, Viton®, *PVC, *Santoprene® 101-55  R5: Ryton®, glass, ceramic, titanium, Viton®, *PVC, *Santoprene® 101-55  *when fully submerged
Transmission Distance	1000 ft (300m)

### 3.4. Dimensions

#### 3.4.1. PTXR5

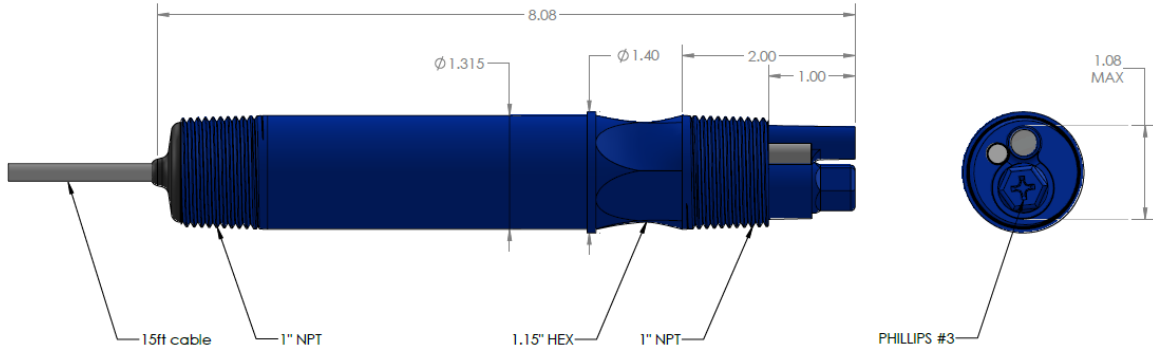

#### 3.4.2. PTXR5-M12



#### 3.4.3. PTXR8

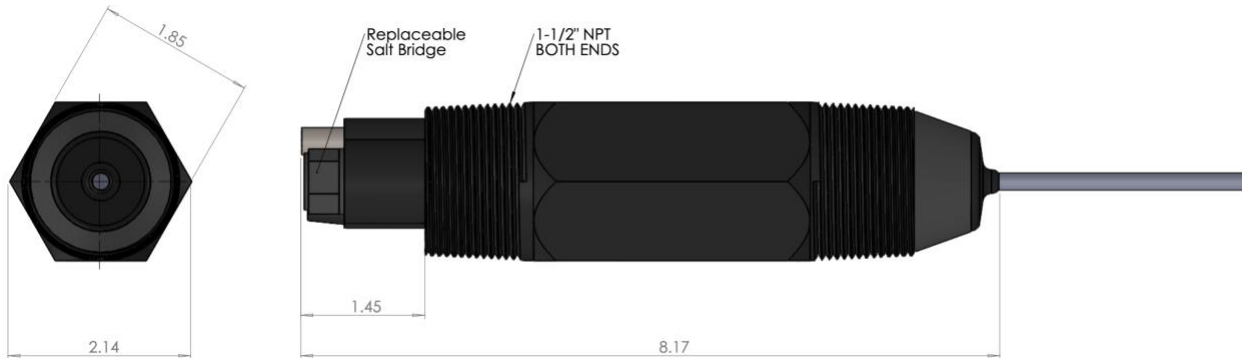

### 3.4.4. PTXR8-M12



## 3.5. Cable

### 3.5.1 PTXR5 and PTXR8

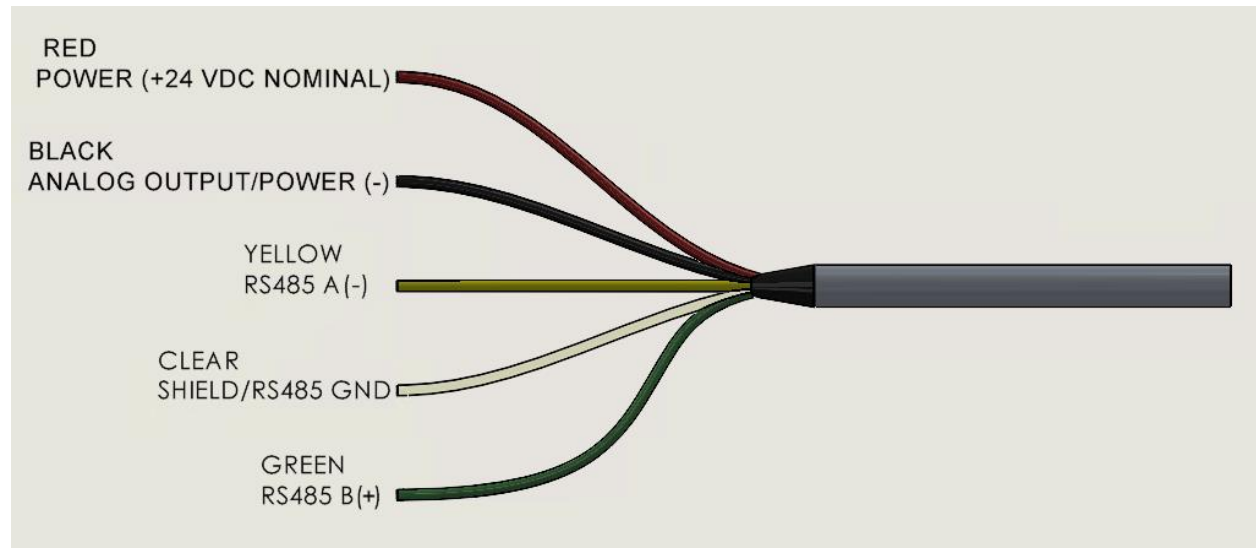

### 3.5.2 PTXR5-M12 and PTXR8-M12

Pin #	Wire Color	PTXR5-M12
1	Red	Power IN (24VDC)
2	Yellow	Digital RS-485 A (-)
3	Black	4-20mA OUT
4	White	Digital RS-485 Shield
5	Orange	Not used
6	Blue	Not used
7	Green	Digital RS-485 B (+)
8	Purple	Not used



Front View  
Not to Scale

### 3.6. Connections to Power Supply and Controller

Wire color	Description
Red	Power (24 VDC nominal)
Black	Analog Output (mA mapping configured using RS485 connection) OR Power (-) (if using RS485 connection only)
Clear	Shield/RS485 Ground
Green	RS 485 B (+)
Yellow	RS 485 A (-)

- 1) The two RS485 wires can be cut, but should not be shorted, if the user does not need PC monitoring or firmware updates.
- 2) Power supply: Nominal 24VDC. Make sure to follow the wiring instructions above and provide the proper power. Connecting the probe to any power outside the normal range may result in damage and may void the warranty.

## 4. Installation

### 4.1. Analog Connections

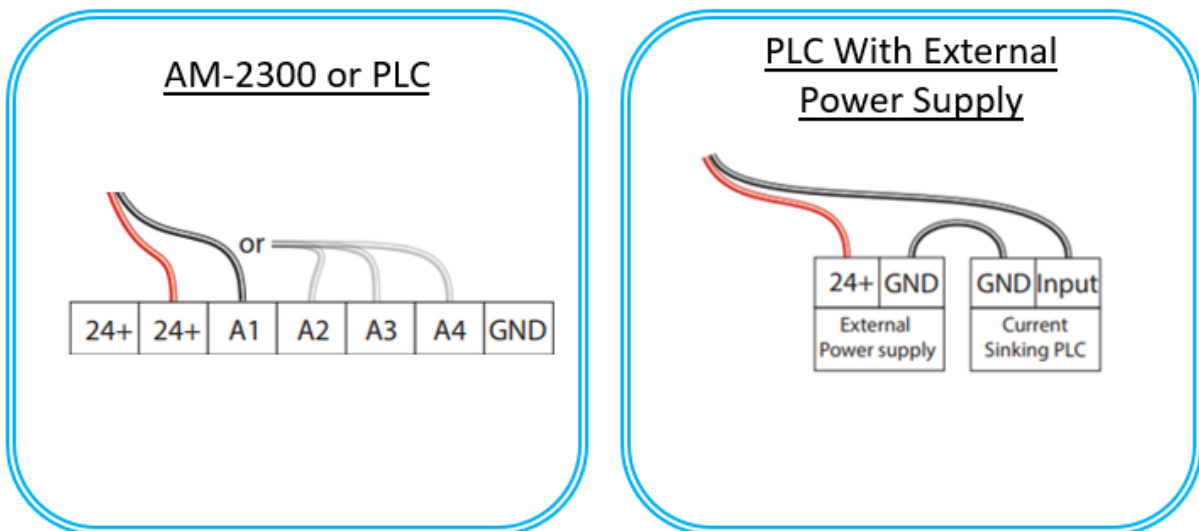

Note: the 4-20mA mapping is defaulted to 0-14pH. For custom ranges, use the Digital communication protocol or contact the Water Analytics Team.

## 4.2. Digital (RS485) Connections

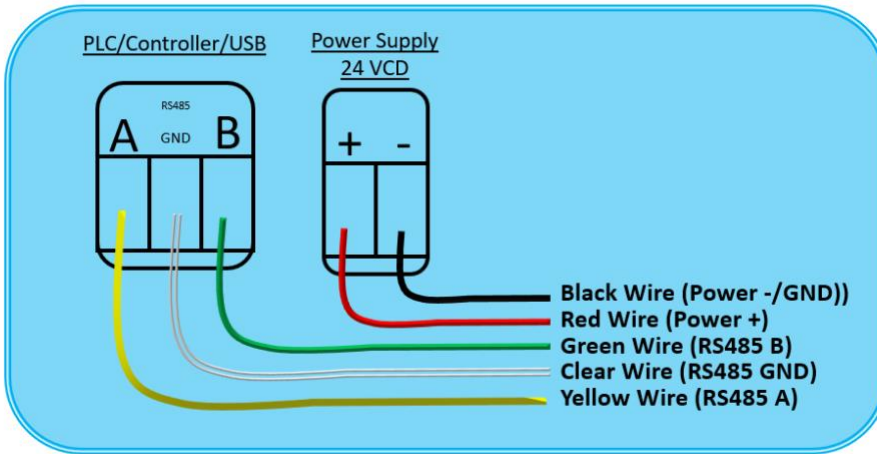

Note: Digital communication is currently available over RS485 and via CLI commands. The Modbus RTU protocol will be available in future releases.

## 5. Digital Communication PC Configuration:

### 5.1. Getting Started

- 5.1.1. Download and install any terminal emulator that supports serial port (we recommend Tera Term or Docklight, but feel free to use your own)
- 5.1.2. Make sure the USB-RS485 ModBus Converter is plugged into the USB port of your PC.
- 5.1.3. Open terminal emulator and then select Serial and identify the correct USB port
- 5.1.4. For emulators like Tera Term, we recommend turning on "Local Echo" in the settings.

### 5.2. Port Configuration:

- a. Speed – 9600
- b. Data – 8 bit
- c. Parity – none
- d. Stop bite – 1 bit
- e. Receive setting as "CR" and Transmit "CR+LF"



(NOTE: For FW3.1 and older Transmit should be set to only "CR" and all commands need a colon ":" at the end

### 5.3. Supported Commands

Please note commands are cAsE sEnSiTiVe:

Commands	Description
<b>calibpHVal</b>	Returns the present factory calibrated pH value.
<b>RawORP</b>	Returns the Raw, uncalibrated mV reading of the sensor
<b>calibTempVal</b>	Returns the present temperature in °C.
<b>Point20</b>	Returns conductivity value set for 20mA output
<b>set4mA: &lt;VALUE&gt;&gt;</b>	Set conductivity for 4mA point (where <<VALUE>> is pH in units of pH) (user can choose any value between 0 and 14 pH with up to 2 decimal points) Default is 0
<b>set20mA:&lt;VALUE&gt;&gt;</b>	Set conductivity for 20mA point (where <VALUE>> is pH in units of pH (user can choose any value between 0 and 14pH with up to 2 decimal points). Default is 14
<b>TempCal:0</b> <b>TempCal:1:&lt;&lt;VALUE&gt;&gt;</b> <b>TempCal:S</b>	Set the reference temperature to <VALUE>> degrees (°C) and start the single point temperature calibration routine. Prints the measured temperature and asks user to select the stable temperature value to set the offset . <b>TempOffset = Measured_Temperature - Reference_Temperature</b> (User can choose any standard Ref temperature for calibration).
<b>pHCal:0</b> <b>pHCal:1: &lt;&lt;VALUE&gt;&gt;</b> <b>pHCal:2: &lt;&lt;VALUE&gt;&gt;</b> <b>pHCal:3: &lt;&lt;VALUE&gt;&gt;</b> <b>pHCal:S</b>	pH Calibration process <b>pHCal:0:</b> is the initiation of the calibration <b>pHCal:1:&lt;&lt;VALUE&gt;&gt;</b> through <b>pHCal:3:&lt;&lt;VALUE&gt;&gt;</b> are the 2 to 3 reference values of the desired calibration points. These should always be done in ascending order, i.e. 1=4pH, 2=7pH and 3=10pH <i>NOTE: The sensor should be stabilized in each solution prior to entering the command for calibration.</i> <b>pHCal:S:</b> saves the calibration  <i>NOTE: for FW V3.1 and older only 2-point cal is possible. The sensor is able to be updated via RS485 connection, please contact WA team for the latest FW.</i>
<b>getpHCP</b>	Returns the calibrated pH points paired with reference values used in calibration. Will also include slope(s) and offset(s)
<b>gettempCP:</b>	Returns the calibrated temp point paired with reference values used in calibration. Will also include temp offset

#### 5.4. Sensor Start up (over RS485)

Display information will include calibration data as well as FW version.

{include screenshot}

## 6. Calibration

The P-TX sensor comes with a factory calibration and is ready to use as is. The P-TX has a mA output that is linear with default values of 4 mA = 0 pH and 20 mA = 14pH (if custom ordered, this range may be

different for you, please refer to the sales order, test cert or information display at the start up of RS485m communication in the terminal emulator). To improve the error at any specific point within the range, it is recommended that the user perform a user calibration around the point of interest. The further away from the user-specified point of interest, the greater the error. It is also possible for the user to adjust the range using the RS485, but as the range is increased the accuracy of the sensor will decrease.

Calibration can be done by one of the following methods, please note the more points used the better the accuracy will be across the desired range of measurement:

- Two-point or multipoint calibration at the Controller or PLC
- Two-point or three-point calibration via RS485 commands\*

*\*NOTE: for FW V3.1 and older only 2-point cal is possible. The sensor is able to be updated via RS485 connection, please contact WA team for the latest FW.*

### 6.1. 2 or 3 Point Calibration saved Direct to Sensor Using RS485

P-TX sensors also have a digital interface that a user can access through a serial communication protocol RS485. The full list of commands can be found in section 5.3.

1. Initiate the pH calibration process by entering the command `pHCal:0`.
2. Insert the Sensor into the desired calibration solution and allow the Sensor readings to stabilize.
  - a. ~1min (for each point)
3. Enter the command "`pHCal:X:<<VALUE>>`" in the terminal emulator window and start the multi point pH calibration routine, the PTX will print the measured mV value in the emulator window as it is captured.
4. Remove the sensor from the first calibration or reference solution and clean it in DI water and wipe it dry.
5. Insert into the next solution again waiting for the reading to stabilize
6. Calibration can be done with 2 or 3 points. These should always be done in ascending order, i.e. 1=4pH, 2=7pH and 3=10pH.
7. To save the calibration simply enter the command `pHCal:S:` after the 2<sup>nd</sup> or 3<sup>rd</sup> point has been saved.

### 6.2. Calibration using AM-2300 Controller (4-20mA)

Calibration using the AM-2300 can be done two ways, via the front panel or via the web interface. For the most accurate calibration, two calibration standards are necessary. In most cases, pH4 & pH7 buffer solutions are recommended due to their wide availability and fast response time. If the process operates in high pH - use pH10 buffer.

In extreme situations, one can substitute calibration solution(s) with a factory default values: 4mA = 0pH, 20mA = 14pH. This method is not recommended as standard calibration practice as accuracy can be much lower, and there is no good way of calculating important metrics like slope and offset.

Front Panel.

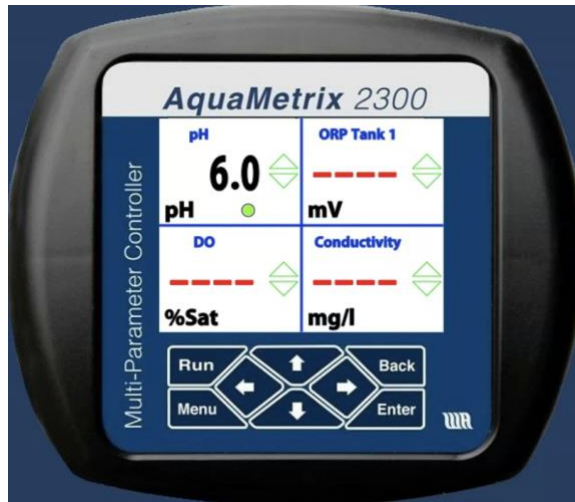

1. Press the **Menu** button.
2. Select **Calibrate/Disable Probe**.
3. Select the sensor (“meter”) from the list of sensors using **↑** and **↓** buttons.
4. Select **Perform Calibration**.
5. The current calibrations values will be displayed. These are the values that were defined when the sensor was first set up.

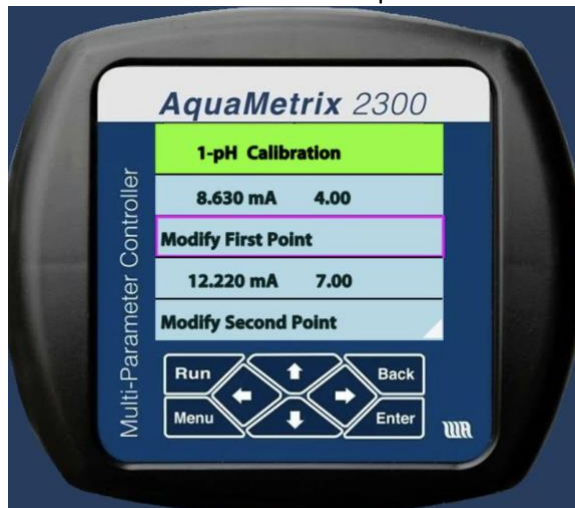

6. Select **Modify First Point**.
7. Insert the pH probe into the lower pH solution (for example, pH4 buffer). The live mA reading will appear on the line **Use Measured mA**. Depending on the probe condition, it may take up to 2 minutes for the reading to stabilize. When the reading is stable select **Use Measured mA** and press **Enter**.



8. In case a pH solution was different from the one stored in previous calibration, update the solution value. Select **Enter Solution Value**. Using the numeric keypad, enter the value of the pH standard—in this example, 4.
9. Confirm the first point calibration by selecting **Confirm Calibration**.
10. Repeat for the second calibration standard (pH7 or pH10 buffer).
11. When both points are updated, leave the calibration menu by either pressing **Run** or selecting **Done**



If you only have one standard, then you must assume the value of the other, using Table 1. For instance, if you only have pH 10 solution then you can assume 8.57 mA for pH 4.

Table 1 lists nominal outputs for pH when the mA mapping range is 0-14.

Output (mA)	pH
4.00	0
8.57	4
12.00	7
15.43	10
20.00	14
Ideal Slope	1.143 mA/pH

Table 1 - Nominal outputs for pH sensors

One should check an offset (difference from an ideal mA output) and a span (difference between two pH solutions) to validate calibration.

A large offset (exceeding  $\pm 1.0$  mA) usually indicates reference solution poisoning. Slope is measured by the difference between two solutions (for example pH4 and pH7) and it should be in the range of 1.085 to 1.143 mA/pH for a new PTX sensor. Over time the slope would degrade, and once the slope drops below 0.972 mA/pH for a probe in service, it is recommended to perform maintenance (cleaning and/or salt-bridge replacement).

Slope can also be expressed as efficiency, which is a percentage value of the nominal (ideal) slope.

$$Efficiency = \frac{Calculated\ Slope}{Ideal\ slope} \times 100\%$$

Efficiency is an easier to understand slope value, where 100% is ideal theoretical slope and low value (0-30%) indicates faulty probe. Acceptable efficiency for a brand new PTX probe is 95%. An efficiency of 85% or lower is a flag for maintenance

### Web Interface

Calibration is part of the probe setup process. However, it can (and should) be done on a periodic basis without going through the entire setup process:

1. The default screen is Probe Status. On the top-level menu select [Setup](#).

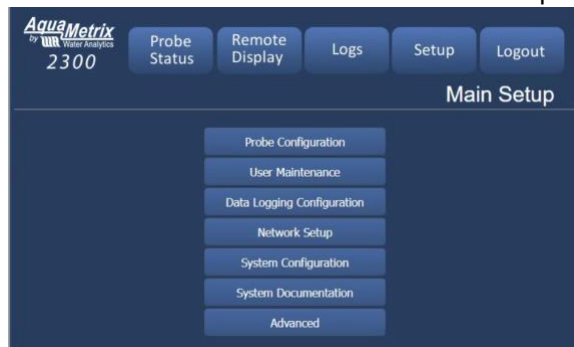

2. On the Main Setup screen select [Probe Configuration](#).
3. On the Probe Configuration screen select the pH probe from the list of probes.

- The first page of the Setup Wizard will appear. Since you are not going through the entire setup process you will select [Summary](#).

Probe 1 Configuration Wizard (Type: Analog Monitor - Analog Input 1)

This page allows you to review all information entered. Please review and press [Submit] when done.

Enter Probe Name  
pH

Scaling/Calibration Type  
Linear (2 points)

Probe Enabled?

Low milliAmp Value  
8.63

Scaled value displayed at low input Value  
4.00

High milliAmp Value  
12.22

Scaled value displayed at high input Value  
7.00

Digits after Decimal Place  
1

Number of Significant Digits  
3

- Immerse the probe in the first calibration solution. Enter the value of the first standard in the field [Scaled value displayed at low input value](#). For the case of pH 4 standard that value is 4.00.
- Click on [Read mAmp Value](#).
- Repeat for the second calibration standard.

If you only have one standard, then you must assume the value of the other. For instance, if you only have pH 10 solution then you can assume 8.57 mA for pH 4.

### 6.3. Two-Point or Multi-Point Calibration with a Controller or PLC

The operations in this step may differ from controller to controller and PLC to PLC, so please refer to the respective manual of the controller or PLC connected to the P-TX. Analog probes are typically scaled/calibrated using linear (2-point) scaling or non-linear (multiple points) scaling. In most cases 2-point scaling is sufficient. Keep in mind that scaling using multiple points often does not apply a best-fit curve through the points, depending on the controller or PLC. They simply connect the individual points and interpolate between two points to generate a number.

- Insert the Sensor into the desired calibration solution and allow the Sensor readings to stabilize.
- Allow the Sensor readings to stabilize. (~1min (for each point))
- Capture the reading in the controller or PLC
- Remove the sensor from the first calibration or reference solution and clean it in DI water and wipe it dry.
- Then repeat the point calibration process from steps 1-3 in a new calibration or reference solution.

A custom calibration routine that allows entering two mA values corresponding to standard buffer solutions (as described above) is ideal, as it ensures better accuracy across the measurement range. However, some PLCs only support scaling at fixed endpoints — typically 4 mA = 0 pH and 20 mA = 14 pH — without the ability to perform a true two-point calibration based on buffer values. In such cases, it's recommended to implement a custom routine within the PLC that mimics two-point calibration using measured mA values from known buffer solutions.

Below is an example of PLC logic that only allows 4 mA and 20 mA point adjustments:

1. Enter first calibration [for example, pH = 4]
2. Enter mA of first calibration solution [for example, mA = 8.9]
3. Enter second calibration [for example, pH = 7]
4. Enter mA of second calibration solution [for example, mA = 12.1]
5. Calculate Slope (pH/mA):  $\Delta\text{pH}/\Delta\text{mA}$  [in the example,  $(7 - 4) / (12.1 - 8.9) = 0.94$ ]
6. Calculate Offset (pH):  $7 - (\text{mA}@\text{pH}7 \times \text{Slope})$  [In the example,  $7 - (12.1 \times 0.94) = -4.34$ ]
7. Calculate pH for 4mA point:  $(4 \times \text{Slope}) + \text{Offset}$  [ $(4 \times 0.94) - 4.34 = -0.59$ ]
8. Calculate pH for 20mA point:  $(20 \times \text{Slope}) + \text{Offset}$  [ $(20 \times 0.94) - 4.34 = 14.41$ ]

Slope and offset calculated in steps 5&6 can be used as a probe's health metric:

- Large offset (exceeding  $\pm 1.0$  mA) usually indicates reference solution poisoning (salt-bridge replacement)
- Slope below 0.972 mA/pH flags for maintenance (electrode cleaning).

## 7. Maintenance

There are three sensor components that require routine maintenance:

1. **Process electrode.** The process electrode of a pH probe is pH-sensitive glass. This electrode needs to be kept clean, which usually means free of biofilms and/or scaling.
2. **Reference Solution.** The reference solution should be for a pH probe, typically pH 7 buffer. As the probe ages reference solution flows out of the salt bridge while the process flow into the junction and into the reference chamber. The result is a steady contamination of reference solution. The pH trends toward 7 as the reference solution more closely resembles the process.
3. **Salt Bridge.** The salt bridge will foul over time through the accumulation of suspended solids and organic matter. The result is that the probe responds increasingly sluggishly and erratically.

The frequency of maintenance depends strongly on the application. Probes in clean water can go for months without the need for cleaning and recalibration but only two weeks in a metal plating operation. Fortunately, by calibrating on a regular basis, one can determine when maintenance is due.

## 7.1. Probe Cleaning

1. Rinse the probe and use a soft brush, e.g. a soft toothbrush, and detergent to gently remove loose debris. Be careful: *The process electrode of a pH probe is comprised of very thin glass and breaks easily. Breaking it is the death of the probe.*
2. Rinse with clean warm water. Tap water is fine.
3. For scaling (calcium carbonate deposits) soak the probe in a weak acid for about an hour. White vinegar works great. Hydrochloric or sulfuric acid diluted ten-fold will do the job in about 10 minutes.
4. For biofilm fouling soak the probe in bleach for about 20 minutes.
5. Rinse the probe again in water.
6. Calibrate the probe in accordance with the instrument instruction manual.

## 7.2. Replacement of Salt Bridge

### **For R5 Series, Differential Probes**

1. If the system cannot be calibrated after cleaning the probe, it may be necessary to replace the reference solution. A kit is available from Water Analytics for this purpose (Part No. AM-SBK3-R5). Proceed as follows:
2. Hold the probe vertically with the sensor face up. Insert Phillips #3 in the salt bridge or wrench and turn counter-clockwise taking care not to damage the glass electrode. Discard the used salt bridge.
3. Up-end the probe and pour out the contents of the standard electrode chamber. Flush the chamber with a small amount of pH 7 buffer or clean water.
4. Refill the chamber with 7pH buffer solution up to the tip of the electrode inside the chamber. DO NOT OVERFILL. It is important to leave space for the salt bridge thread and a small amount of air.
5. Screw the new salt bridge into the cavity until finger tight. Now turn 1/4 turn using a wrench of Phillips #3. The top o-ring of the salt bridge should not be visible.

### **For Series 8 Differential Probes**

1. If the system can't be calibrated after cleaning the probe, it may be necessary to replace the standard cell solution and/or the salt bridge. A salt bridge kit is available from Water Analytics for this purpose (Part No. AM-SBK3-8R). Proceed as follows:
2. Hold the probe vertically electrodes up. Remove the used salt bridge. For the -8 probe the salt bridge is a hexagonal-shaped capsule that can be removed using a 9/16" socket wrench. Discard the used salt bridge.
3. Dispose of the used solution inside the bridge chamber and flush with pH 7 solution or distilled water.
4. Refill the chamber with 7pH buffer solution, up to the tip of the electrode, inside the chamber. DO NOT OVERFILL. It is important to leave space for the salt bridge thread and a small amount of air.
5. Screw the new salt bridge into the cavity until finger tight. Now perform a 1/4 turn with a 9/16" socket wrench. The salt bridge edges should be flush with the front of the probe face.

### 7.3. Storage

1. Do not discard the protective cap(s) that came with the sensor. If the sensor is removed from the process for an extended period of time, thoroughly clean the sensor, put a piece of cotton ball with few drops of water into the protective cap and replace it on the sensor. This keeps the junction from drying out which causes slow response when put back into operation or causes permanent damage to the sensor. **Sensors should not be left in dry lines or empty tanks for extended periods.**
2. Do not store the sensors in a dry or humid location. When storing, check the protective cap(s) regularly to make sure the cotton ball remains moist. Improper storage of sensors voids the warranty.

## 8. Accessories/Replacement/Spare Parts

<p>2" Sanitary Flange -R8: AM-SFL-8 -R5: AM-SFL-5</p>		<p>Union Tee with adapter  -R8: AM-TEE-8 -R5: AM-TEE-5</p>	
<p>Protectors -R8: AM-PTR-8 -R5: AM-PTR-5</p>		<p>Jet Cleaners -R8: AM-JET-8 -R5: AM-JET-5</p>	
<p>Salt Bridge Kit (3-pack) -R8: AM-SBK3-R8 -R5: AM-SBK3-R5</p>		<p>Salt Bridge Kit (10-pack) -R8: AM-SBK10-R8 -R5: AM-SBK10-R5</p>	
<p>*Hot Tap Assembly -R5: AM-HTA-R5</p>		<p>*Submersion Hardware -R8: AM-ARM-8 -R5: AM-ARM-5</p>	
<p>Junction box AM-JB2</p>		<p>*Interconnect cable: AM-CBL</p>	
<p>pH Calibration Solutions (500ml) pH4: AM-PH4-1P pH7: AM-PH7-1P pH10: AM-PH10-1P</p>			
<p>*not compatible with PTXR5-M12 and PTXR8-M12</p>			

## 9. Mounting

### 9.1. Mounting Options for R8 sensors

#### 9.1.1. Submersion Mounting

Note: PTXR8 is not compatible with AM-ARM-8 mounting hardware.

Refer to *Figure 2* below.

1. A submersion mounting kit, AM-ARM-8, is available from Water Analytics which includes 4 ft. of 1" CPVC pipe, 1-1/2" x 1" reducer, a strain relief fitting and wire mounting bracket. Proceed as follows, either with the kit or with your own hardware.
2. Route the sensor cable through a pipe. Apply a thread sealant to the thread on the cable end of the sensor and screw it into a 1-1/2" fitting. Tight the strain relief. The cable end of the sensor should not be exposed to the process. A cable strain relief fitting should be used on the upper end of the pipe. In the kits a wire bracket is provided to aid in supporting the assembly.

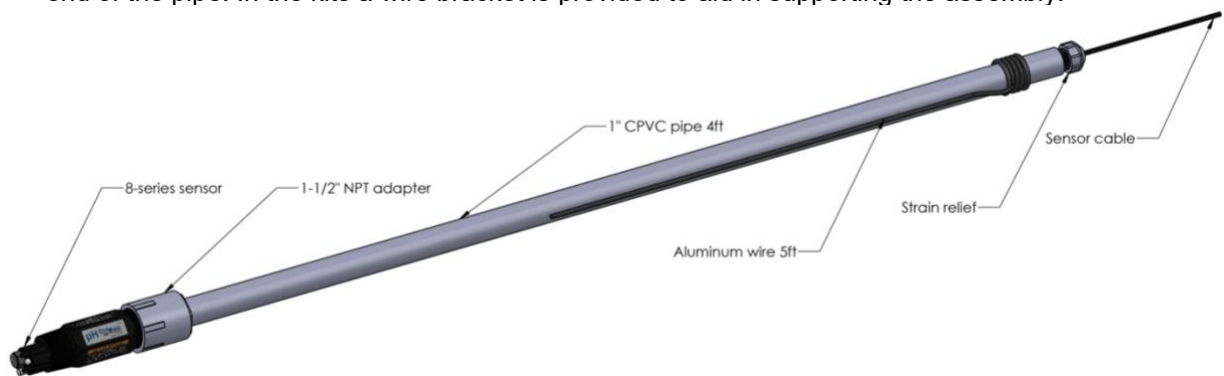

*Figure 2 - Submersion mounting using AM-ARM-8*

An optional protective shroud, Part No. AM-PTR-8 should be used on the electrode end of the sensor to protect the electrodes from accidental contact with the tank bottom, sides or objects in the process. See *Figure 3* below.

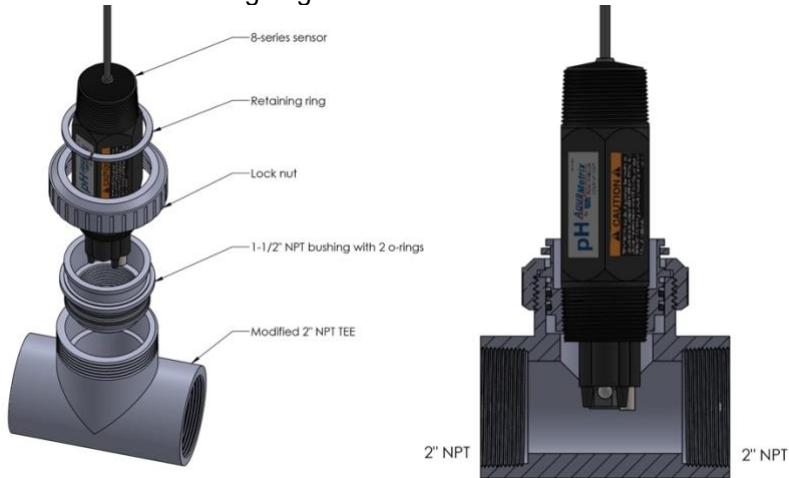

*Figure 3 - Electrode protector AM-PTR-8 installation*

### 9.1.2. Flow-through mounting in a TEE

Refer to *Figure 4* below

1. Apply pipe sealant to the electrode end of the sensor and screw it into the 1-1/2" NPT bushing.
2. Slide bushing into modified TEE
3. Secure sensor by tighten the lock nut
4. Install retaining ring

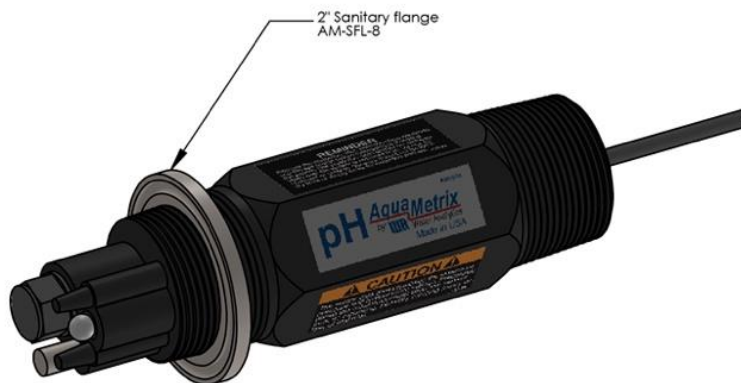

*Figure 4 - Flow through installation using AM-TEE-8*

### 9.1.3. Sanitary fitting for R8-series

Note: the sanitary fitting doesn't make sensor suitable for sanitary application.

The R8-series can be installed in 2" sanitary fitting using sanitary flange (part AM-SFL-8). Refer to *Figure 5* below. Please note that the sanitary fitting doesn't make sensor suitable for sanitary application.



*Figure 5 - Installation of AM-SFL-8 sanitary fitting*

## 9.2. Mounting options for R5 sensors

### 9.2.1. Submersion mounting

Note: PTXR5-M12 is not compatible with AM-ARM-5 mounting hardware.

1. A submersion mounting kit, AM-ARM-5, is available from Water Analytics which includes 4 ft. of 1" CPVC pipe, 1" adapter, a strain relief fitting and wire mounting bracket. Proceed as follows, either with the kit or with your own hardware.
2. Route the sensor cable through a pipe. Apply a thread sealant to the thread on the cable end of the sensor and screw it into a 1" fitting. Tight the strain relief. The cable end of the sensor should not be exposed to the process. A cable strain relief should be used on the upper end of the pipe. In the kits a wire bracket is provided to aid in supporting the assembly.

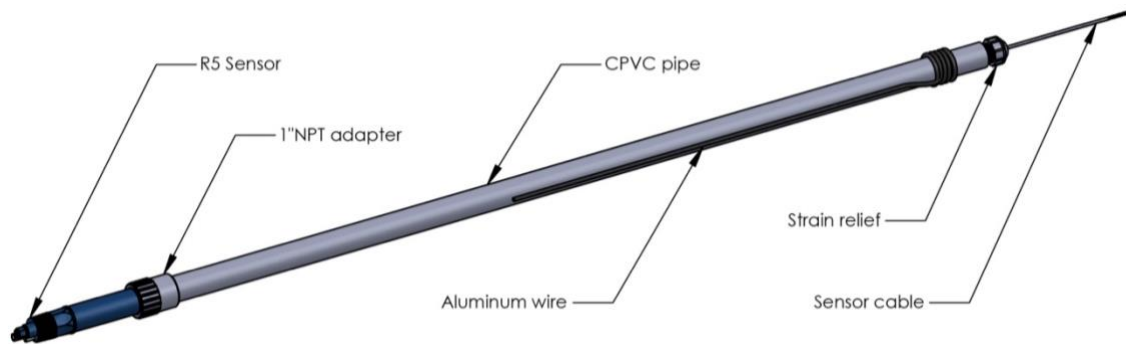

Figure 6 - Submersion mounting using AM-ARM-5

An optional protective shroud, Part No. AM-PTR-5 should be used on the electrode end of the sensor to protect the electrodes from accidental contact with the tank bottom, sides or objects in the process. See Figure 7 below.

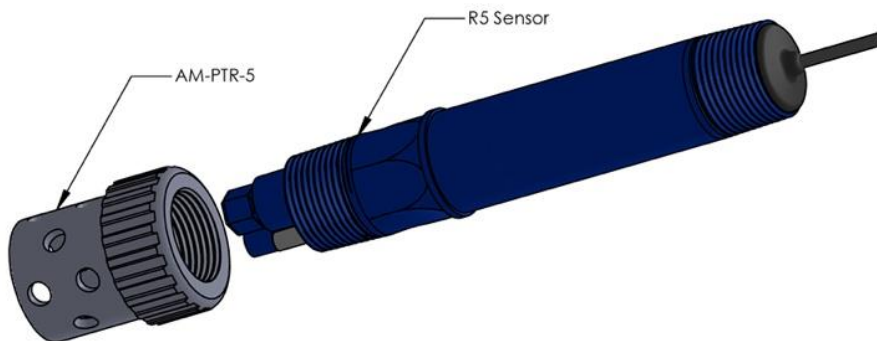

Figure 7 - Electrode protector AM-PTR-5 installation

### 9.2.2. Flow-through tee mounting R8-series Differential Sensors

Refer to Figure 8 below

1. Apply pipe sealant to the electrode end of the sensor and screw it into the 1" NPT bushing
2. Slide bushing into modified TEE
3. Secure sensor by tighten the lock nut
4. Install retaining ring

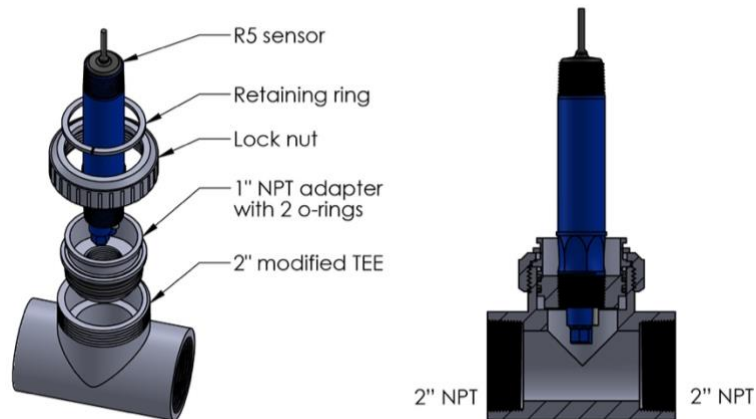

Figure 8 - Flow through installation using AM-TEE-5

### 9.2.3. Sanitary fitting

Note: the sanitary fitting doesn't make sensor suitable for sanitary application.

The R5-series can be installed in 2" sanitary fitting using sanitary flange (part AM-SFL-5). Refer to *Figure 9* below.

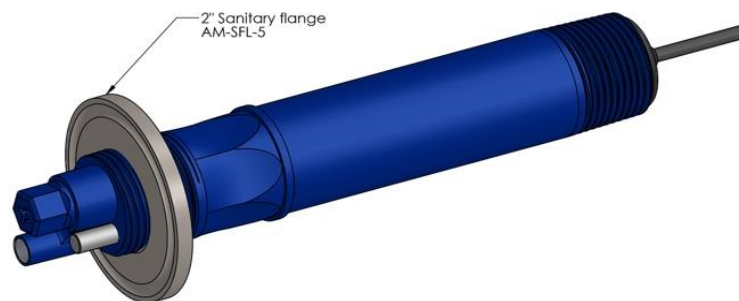
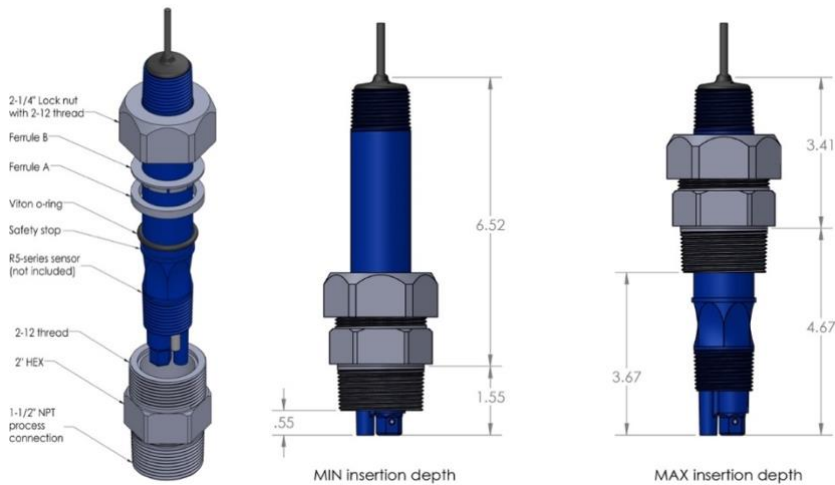

Figure 9 - 2in sanitary flange AM-SFL-5

### 9.2.4. Variable insertion (R5-series only)

Refer to *Figure 10* below.

1. Mount the attachment on the sensor from the cable side.
2. Take the compression fitting apart. Apply pipe sealant to the 1-1/2" NPT thread and screw this part into a 1-1/2" tee or nipple. A larger fitting with an appropriate reducer may be used.
3. Put the compression fitting components on the sensor in the order shown in the figure below.
4. Remove the protective cap from the sensor and place the sensor in the tee. The sensor must be in such a position that the electrodes will be in the pipe stream but not touching the opposite side of the tee.
5. Now tighten the nut by hand as much as possible, then turn 1/2 turn with a wrench.

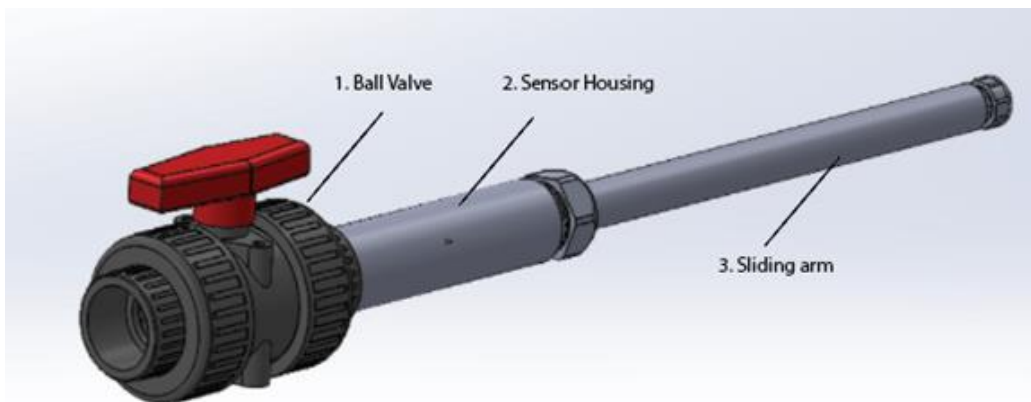

*Figure 10 - Variable insertion using AM-CFT-R5 compression fitting.*

Using attachment AM-CFT-R5 the standard R5 series sensor can be used in applications that require variable insertion. AM-CFT-R5 has 1-1/2" NPT process connection and allow to vary insertion depth from .55" to 3.67"

### 9.2.5. Hot Tap (Wet Tap) insertion mounting R5-series

Note: PTXR5-M12 is not compatible with AM-HTA-R5.



*Figure 11 - AM-HTA-R5 Hot Tap assembly*

1. A ball valve assembly, AM-HTA-R5 (or a shorter version AM-HTA-R5S), is available from AquaMetrix which includes the 2" ball valve, sensor housing, and a sliding arm with cable compression fitting.
2. Take union ball valve apart from both ends.
3. Mount the 2" fitting in a desirable location on a tank or pipe. The assembly comes with a field selectable, 2" FNPT or socket adaptor. Add the ball valve to the union, make sure ball valve is in the closed position.
4. Take the compression fitting at the end of a sliding arm apart.
5. Insert sensor cable into the sliding arm from the 1" adapter side and run it through cable gland.
6. Apply sealant to the back end of the R5-series probe and screw the sensor into the 1" sensor adapter.
7. Re-assemble compression fitting at the end of the sliding arm with the cable installed.
8. Loosen the compression fitting of the sensor housing. Slide the sensor into the sensor's housing fully.
9. Place the union body, with the probe attached, back into the ball valve assembly and tighten union nut.
10. Open ball valve & slide the probe into the process.
11. Tighten the compression fitting nut of the sensor housing by hand as much as possible, then turn 1/2 turn with a wrench to keep probe in place.

## 10. Troubleshooting

To troubleshoot the AM-P-TX connect it directly to the power supply avoiding, if possible, all interconnections, splices, and junction boxes.

The next testing level requires a multimeter in current mode. To test the sensor using a multimeter in current mode, begin by setting the multimeter to measure mA and ensuring the probes are correctly configured (red probe in mA terminal and black probe in COM). Connect the sensor's red wire to the positive terminal of a 24±4 VDC power supply. Disconnect the sensor's black wire from the negative terminal of the power supply (or PLC analog input) and connect it to the red (mA) lead of the multimeter. Then, connect the multimeter's black (COM) lead to the negative terminal of the power supply (or PLC analog input), completing the circuit. The current reading on the multimeter will depend on the solution the sensor is in and the configured 4-20mA mapping. To verify functionality, ensure the solution differs from the current controller or PLC reading to get a new measurement. If the output is stuck at 4mA or 20mA, the sensor may be faulty and require replacement.

The expected reading is dependent on the solution the sensor is in and the 4-20mA mapping. Calculate the anticipated mA value and choose a solution that is different from the current reading on the controller or PLC. If the output is stuck at 4mA or 20 mA – the sensor is not working.

If readings are not accurate the recommendation is to perform calibration as per section 6 and retest.

If calibration was recently done, but accuracy is an issue, then it is recommended to look at the recommended maintenance procedures, including cleaning, salt bridge replacement and refreshing the reference solution. Details of this are outlined in section 7.

The sensor can also be connected via RS485 to a computer and using a terminal emulator, the user can connect and get live readings. If the user is not able to connect, then the sensor is not working.

Please contact [support@wateranalytics.net](mailto:support@wateranalytics.net) or call Water Analytics technical support 978-749-9949

## 11. Disposal

In accordance with local regulations, please dispose of this product at specified locations for electrical and electronic equipment. Please contact the local government/authority or party responsible from which you purchased this device. Should this device be passed on to other parties (for private or professional use), the content of this regulation must also be related.

## 12. Warranty

Water Analytics provides this material as-is and makes no warranties, express or implied, regarding its suitability for any specific purpose. Water Analytics shall not be held responsible for any errors or damages, whether incidental or consequential, arising from the use or performance of this material.

Under no circumstances shall Water Analytics be liable for any direct, incidental, or consequential damages resulting from the sale, manufacture, delivery, or use of any product.

Warranty information available on the website [www.AquaMetrix.com](http://www.AquaMetrix.com) or [www.wateranalytics.net](http://www.wateranalytics.net)

## 13. Contact

Please contact us at [support@wateranalytics.net](mailto:support@wateranalytics.net) or call us at 978-749-9949.

This manual contains confidential and copyrighted information owned by Water Analytics. The contents of this document may not be reproduced, photocopied, or translated into another language without the prior written consent of Water Analytics.



978-749-9949

[www.WaterAnalytics.net](http://www.WaterAnalytics.net)