



OPERATING INSTRUCTION MANUAL



MODELS P575T1, P585T1, R575T1, R575T1 COMBINATION STYLE pH AND ORP SENSORS

N116-27 REV. 8

Water Analytics, Inc.
100 School Street
Andover, MA 01810

Tel: (978) 749-9949

Contents

1	GENERAL INFORMATION.....	3
2	SPECIFICATIONS.....	4
3	INSTALLATION.....	5
3.1	General Instructions	5
3.2	Submersion Mounting for 575-series	6
3.3	Flow-through tee mounting.....	7
3.3.1	575-series	7
3.3.2	585-series	7
3.4	Wiring to an analyzer	8
3.4.1	Wiring to AM-2252 Controller	8
3.4.2	Wiring to AM-2250 Controller	9
3.4.3	Wiring to AM-2250TX Transmitter.....	9
4	SERVICE AND MAINTENANCE	9
4.1	Probe Cleaning	9
4.2	Storage.....	10
4.3	Customer Service	10
4.4	Accessories, pH and ORP Calibration Solutions	10
4.5	Warranty.....	11
	APPENDIX A	12
	APPENDIX B	13

1 GENERAL INFORMATION

This manual covers all AquaMetrix conventional combination sensors. Figure 1 shows all available configurations offered by AquaMetrix. Please note that product highlighted in blue is a standard configuration that is usually ships within 24hr, other configurations are made to order.

Application		
pH		P
ORP		R
Body Type		
1" MNPT threaded ends, fixed insertion		575
3/4" MNPT CPVC compression fitting, variable insertion		585
Temperature Compensation and Electrode Options		
PT1000RTD - standard for all 500-series sensors		T1
Cable Length		
Standard 15 ft (4.5m) cable		015
Extended 50ft (15.24m) Cable		050
Custom cable Maximum recommended cable length is 50 ft		XXX

<u>P</u> <u>575</u> <u>T1</u> - <u>015</u>
--

Figure 1 - Part number for combination sensors

Before placing the sensor into operation, remove the protective plastic cap. Store this cap for future use.

NOTE: If the sensor is removed from the process for an extended period of time, thoroughly clean the sensor, put a piece of cotton ball with few drops of water into the protective cap and replace it on the sensor. This keeps the junction from drying out which causes slow response when put back into operation or causes permanent damage to the sensor. **Sensors should not be left in dry lines or empty tanks for extended periods.**

Do not store the sensors in a dry or humid location. When storing, check the protective cap regularly to make sure the cotton ball remains moist. Improper storage of sensors voids the warranty.

2 SPECIFICATIONS

	pH	ORP
MEASURING RANGES	0.01 to 14.00 pH	-1000 to +1000 mV
WETTED MATERIALS	CPVC body, polycarbonate (or epoxy), ceramic junction, silicone rubber, glass electrode, EPDM Optional: teflon for HF-resistant pH, antimony for HFA	CPVC body, polycarbonate (or epoxy), ceramic junction, silicone rubber, glass electrode, EPDM, platinum
TEMPERATURE LIMITS	23 to 167°F (-5 to 75°C)	
MAXIMUM PRESSURE	100 PSIG at 65°C (6.9 BAR at 65°C)	
TEMPERATURE COMPENSATION	Pt1000RTD None for "HFA" Antimony pH	
MAXIMUM FLOW RATE	10 ft/second (3 meters/sec)	
STABILITY	0.05 pH / day, non-cumulative	3.0 mV / day, non-cumulative
SENSITIVITY	0.01 pH unit	0.1 mV
SENSOR CABLE	Default length 15 ft (4.5m) dual coaxial, tinned wires. Up to 50 ft cable available. Optional BNC connectors	
MOUNTING	575	585
MOUNTING TYPE	Fixed insertion	Variable insertion
MOUNTING	1" NPT thread on both ends	¾" NPT threaded compression fitting

3 INSTALLATION

3.1 General Instructions

Specific instructions for each type of probe are given in the following pages. Common to all probes are the following instructions:

- If the distance between the probe and the instrument is greater than 50ft you will need a preamplifier. Be sure that you have sufficient slack cable to allow for probe removal for calibration and servicing.
- Route the interconnect cable from the junction box to the instrument, preferably in metal conduit. Do not run the power cable or control cables in the same conduit with the probe interconnect cable.
- Remove the protective plastic caps from the end of the probe before placing in service.
- For best results use vertical installation. When vertical position is not achievable, sensor must be at least 15° above horizontal. Do not mount sensor in horizontal position or upside down (see **Error! Reference source not found.**).
- Do not use a pipe wrench on the sensor.

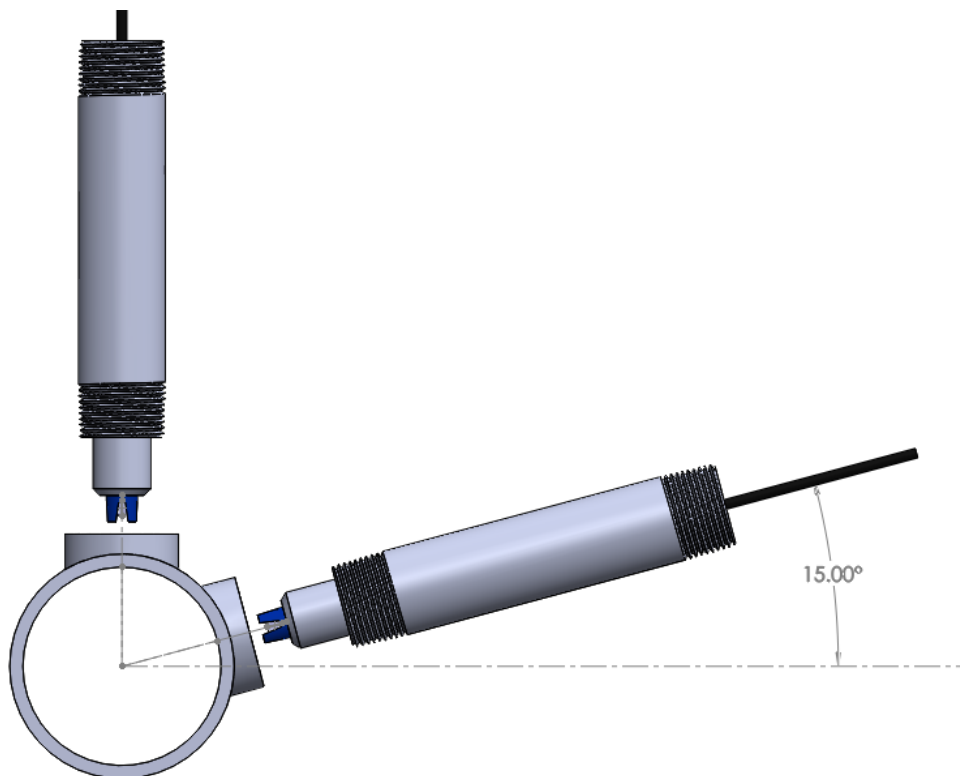

Figure 2 - General mounting instructions

3.2 Submersion Mounting for 575-series

See Figure 3 below.

A submersion mounting kit for 575-series is available from Water Analytics (part# AM-ARM-5) which includes 4ft of 1" CPVC pipe with 1" NPT thread on one end and a strain relief fitting for the cable on the other. Proceed as follows, either with the kit or with your own hardware:

- a) Route the sensor cable through an appropriate length of a pipe.
- b) Apply a thread sealant to the thread on the cable end of the probe and screw sensor into a threaded coupling of AM-ARM-5.
- c) A cable strain relief fitting should be used on the upper end of the pipe. In the kits a wire bracket is provided to aid in supporting the assembly.
- d) To protect cable, the process should not be allowed to come in contact with the cable end of the probe.

Refer to Appendix A (DRAWING# N106-285 R0)

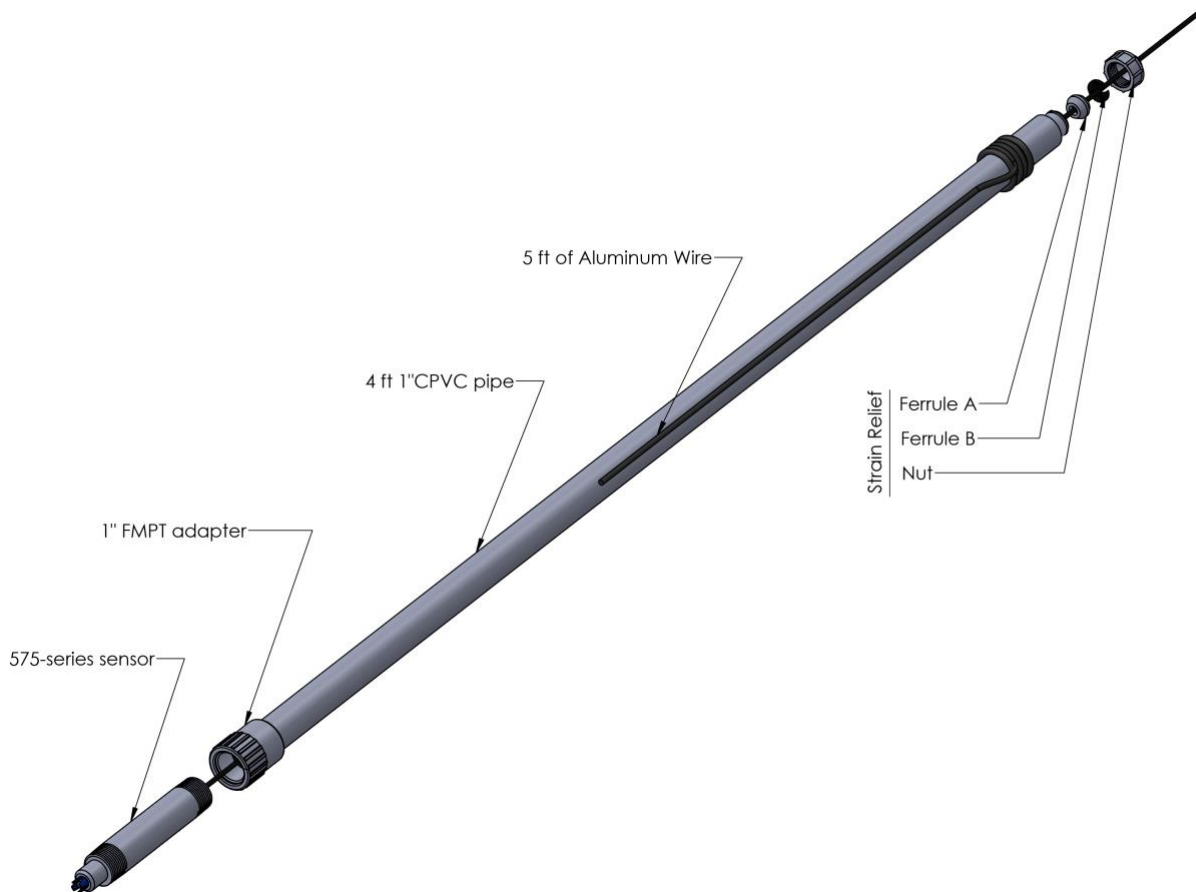

Figure 3 - Submersion mounting for 575-series sensor

3.3 Flow-through tee mounting

3.3.1 575-series

Apply pipe sealant to the electrode end of the sensor. Remove the protective cap from the sensor and screw it into a standard 1" NPT tee. For best results use vertical installation. When vertical position is not achievable, sensor must be at least 15° above horizontal. Do not mount sensor in horizontal position or upside down. See **Error! Reference source not found.**

3.3.2 585-series

See Figure 4 below.

Take the compression fitting apart. Apply pipe sealant to the 3/4" compression fitting thread and screw this part into a 3/4" tee (A larger tee with an appropriate reducer may also be used). Remove the protective cap from the sensor and insert it into the tee. Adjust insertion depth so the sensor is in pipe stream but not touching the opposite side of the tee. Tighten the nut by hands then turn 1/2 turn with a wrench.

Refer to Appendix B (DRAWING # N106-81)

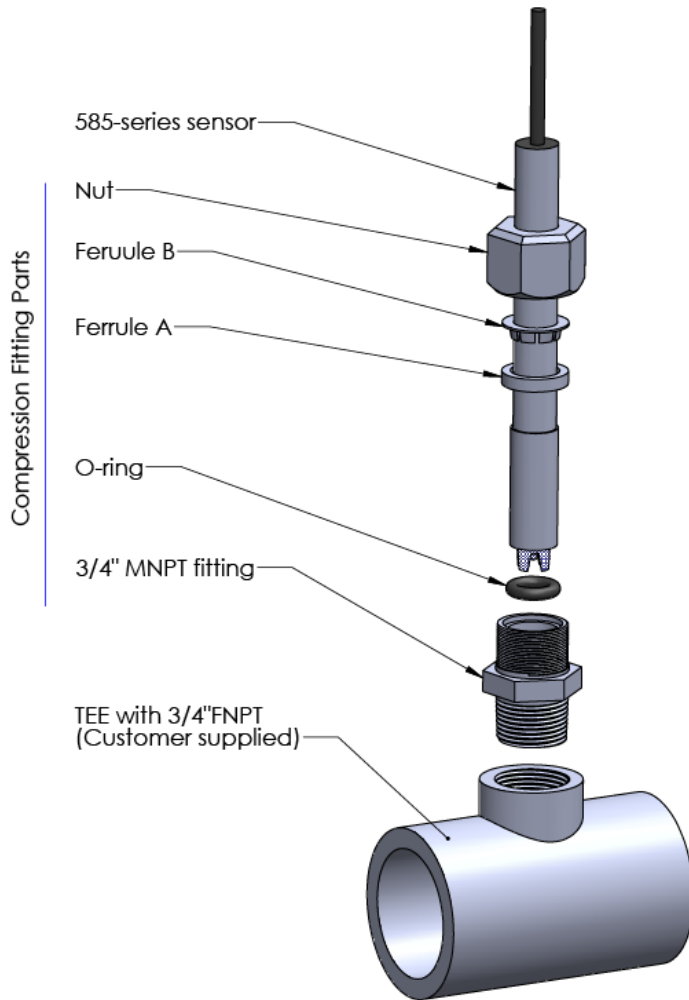

Figure 4 - In-line mounting 585-series sensors

3.4 Wiring to an analyzer

Specific instructions for connecting sensor to Aqua Metrix controllers and transmitters are given in the following pages.

500-series sensor can be connected to virtually any pH/ORP analyzer that accepts two-wire combination input. Some may require BNC connector for process connection, refer to Figure 1 on page 3 to use part number with appropriate connector type (standard type is tinned leads). Analyzers may or may not compensate for temperature; 500-series has four temperature device options with PT1000RTD being default ATC. If your analyzer doesn't have inputs for temperature device (or doesn't support either of four ATC options) and your sensor works in a relatively stable temperature range - leave ATC wires unconnected (White TC and Green TC), the process will still be measured relatively accurate.

Follow these steps when connecting sensor to an analyzer:

1. Always power down the controller/transmitter BEFORE connecting the probe cable.
2. Check the wiring. Use wiring diagrams below to ensure that you've made the correct connections.
3. Remember: Unplug it, wire it, check it and power it.

Please note:

- A jumper wire is required to connect combination sensor. It is shown red on diagram and is not included. Use AWG 20-24 and make sure it has a good connection.
- There are two visually similar wires (pH/ORP is clear and TC is white), make sure that they are not mismatched

3.4.1 Wiring to AM-2252 Controller

500-series sensors can be connected to either input channel of the AM-2252 controller. Two sensors can be connected simultaneously.

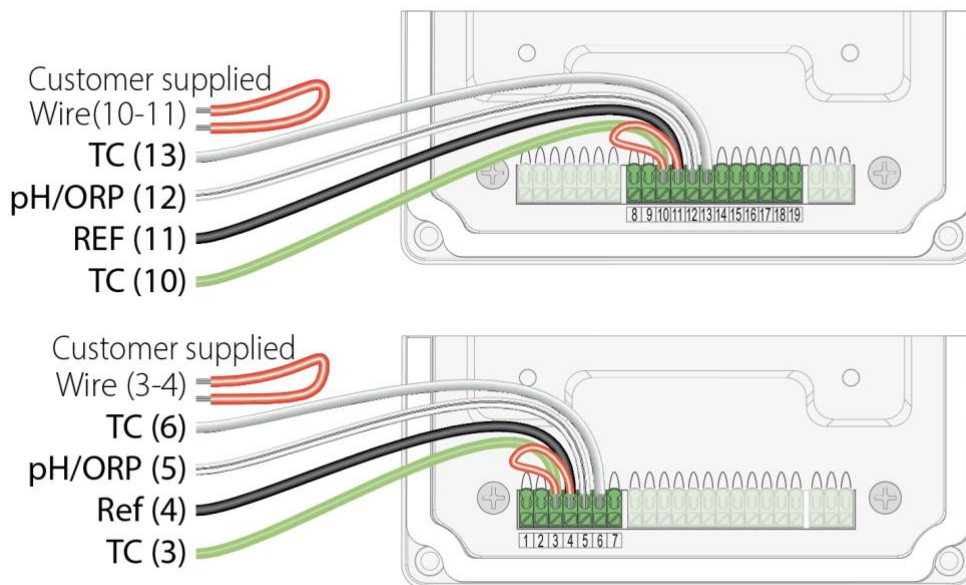

3.4.2 Wiring to AM-2250 Controller

There are two AM-2250 controllers with different connector layout. If your controller was purchased before 2021, the connectors will be labeled 1-15 and the top wiring diagram must be used. For AM-2250 controllers purchased after 2021, the label on the connector will go from 8 through 19– use the bottom wiring diagram.

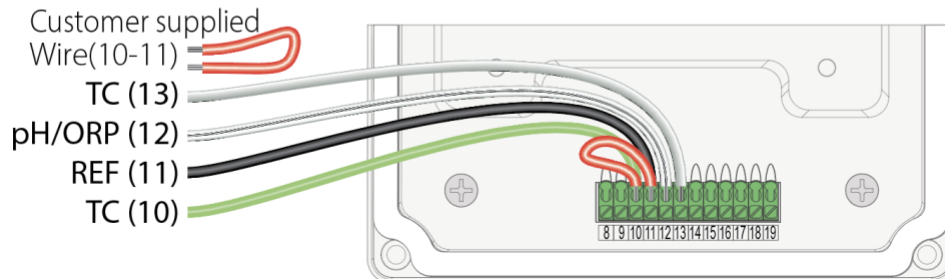
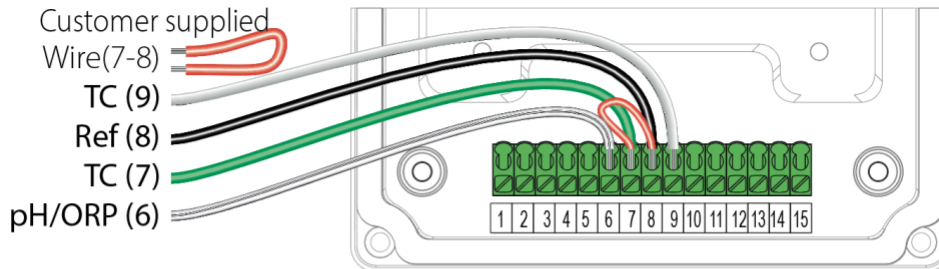

3.4.3 Wiring to AM-2250TX Transmitter

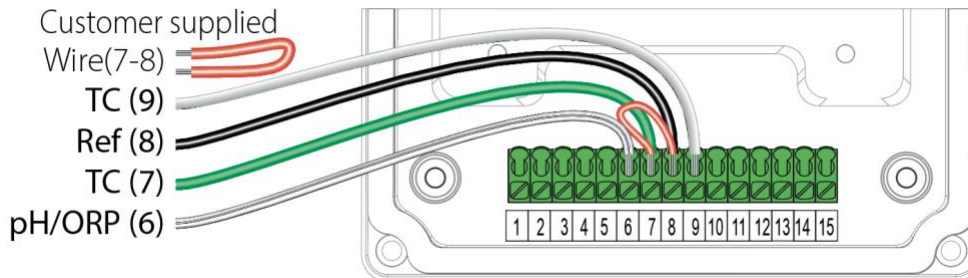

4 SERVICE AND MAINTENANCE

4.1 Probe Cleaning

The probe should be kept reasonably clean to avoid measurement errors. Frequency of cleaning can only be determined by experience. To clean proceed as follows:

- Rinse with clean warm water.
- Soak the end of the probe in warm water and dish detergent for 3 or 4 minutes.

- c) Brush the end of the probe with a soft bristle brush such as a toothbrush. Take care not to scratch the glass electrode.
- d) If the probe is still not clean, it may have to be cleaned with acid.
CAUTION: Do not acid clean probes used in processes containing cyanide solutions. Some experimentation may be required to determine the most suitable acid for your process. Use the most dilute acid which is effective.
- e) Soak the probe for not more than 5 minutes in the chosen acid, then rinse thoroughly with clean warm water.
- f) Calibrate the system in accordance with the instrument instruction manual.

4.2 Storage

Do not discard the protective cap that came with the sensor. If the sensor is removed from the process for an extended period of time, thoroughly clean the sensor, put a piece of cotton ball with few drops of water into the protective cap and replace it on the sensor. This keeps the junction from drying out which causes slow response when put back into operation or causes permanent damage to the sensor. **Sensors should not be left in dry lines or empty tanks for extended periods.**

Do not store the sensors in a dry or humid location. When storing, check the protective cap regularly to make sure the cotton ball remains moist. Improper storage of sensors voids the warranty.





4.3 Customer Service

If a problem has not been resolved with the above procedures, a telephone consultation with your AquaMetrix representative or directly with Water Analytics will provide the answer.

Tel: (978) 749-9949
Email: support@WaterAnalytics.net

4.4 Accessories, pH and ORP Calibration Solutions

The accessories and pH Buffers and ORP Calibration Solutions are listed below. When ordering parts please use the complete part number.

<p>pH Calibration Solutions (1 pint ≈ 500ml) pH4: AM-PH4-1P pH7: AM-PH7-1P pH10: AM-PH10-1P</p>		<p>ORP Calibration Solutions (1 pint ≈ 500ml) 200 mV: AM-R200-1P 600 mV: AM-R600-1P</p>	
<p>pH Calibration Solutions (1 gal ≈ 4L) pH4: AM-PH4-1G pH7: AM-PH7-1G pH10: AM-PH10-1G</p>		<p>ORP Calibration Solutions (1 gal ≈ 4L) 200 mV: AM-R200-1G 600 mV: AM-R600-1G</p>	

<p>Protector for 575-series sensor: AM-PTR-5</p>		<p>Jet Cleaner for 575-series sensor: AM-JET-5</p>	
<p>Union Tee with adapter for 575-series sensor: AM-TEE-5</p>		<p>Submersion Hardware for 575-series sensor: AM-ARM-5</p>	

4.5 Warranty

Warranty information is available on the website www.AquaMetrix.com or www.wateranalytics.net .

Appendix A

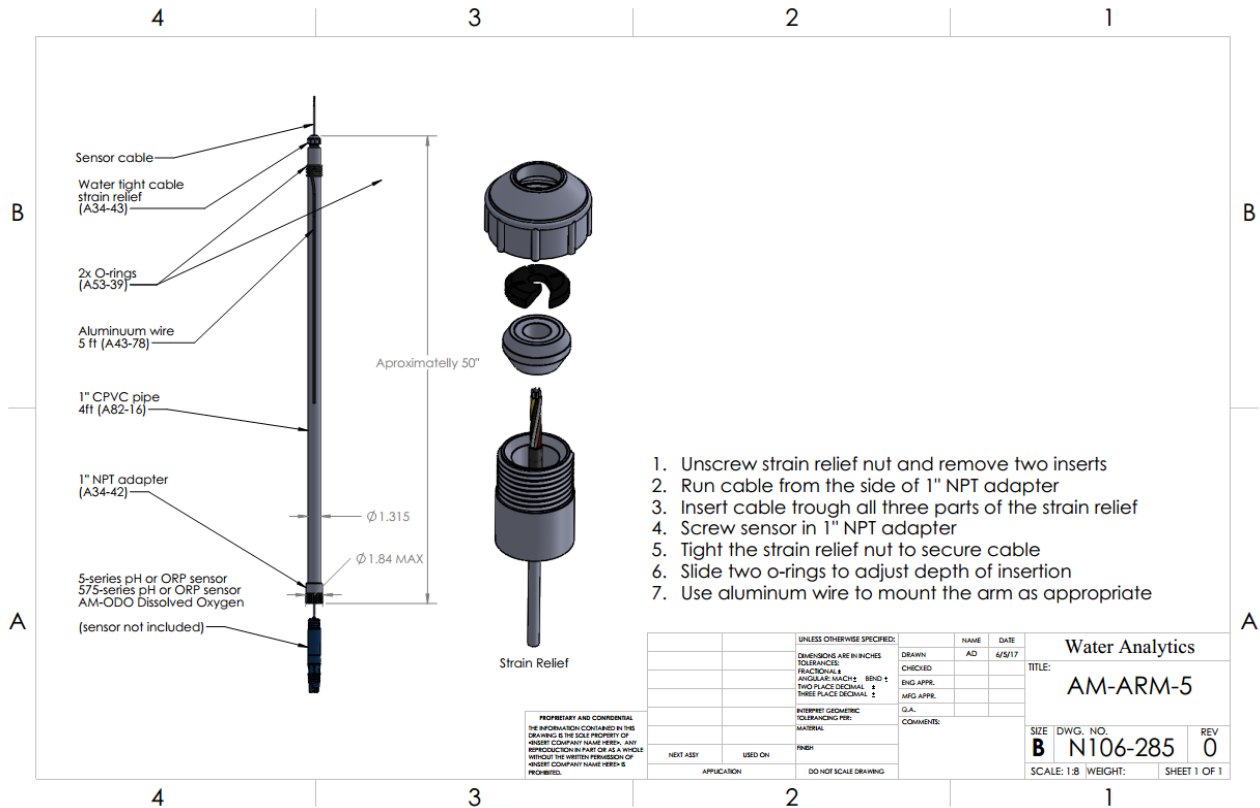

PROPRIETARY AND CONFIDENTIAL
 THE INFORMATION CONTAINED IN THIS
 DRAWING IS THE SOLE PROPERTY OF
 HANSON COMPANIES. ANY
 REPRODUCTION IN PART OR AS A WHOLE
 WITHOUT THE WRITTEN PERMISSION OF
 HANSON COMPANIES IS PROHIBITED.

UNLESS OTHERWISE SPECIFIED:		NAME	DATE
DIMENSIONS ARE IN INCHES	DRAWN	AD	6/5/17
TOLERANCES:	CHECKED		
FRACTIONALS & ANGULARS: MATCH	ENG APPR.		
TWO PLACE DECIMAL: #	ARG APPR.		
THREE PLACE DECIMAL: #	C.A.		
	COMMENTS:		
FINISH			
APPLICATION			

Water Analytics	
TITLE: AM-ARM-5	
SIZE: B	DWG. NO: N106-285
REV: 0	SHEET 1 OF 1

Appendix B

4	3	2	1
---	---	---	---

B
B

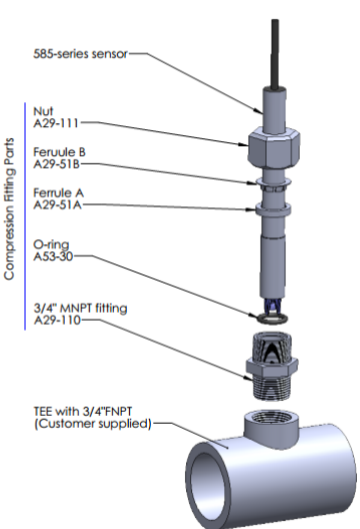

Compression Fitting Parts
 Nut A29-111
 Ferrule B A29-51B
 Ferrule A A29-51A
 O-ring A53-30
 3/4" MNPT fitting A29-110
 TEE with 3/4"FNPT (Customer supplied)

1. Take the compression fitting apart.
2. Apply pipe sealant to the 3/4" compression fitting thread and screw this part into a 3/4" tee. A larger tee with an appropriate reducer may also be used.
3. Remove the protective cap from the sensor and insert it into the tee.
4. Adjust insertion depth so the sensor is in pipe stream but not touching the opposite side of the tee.
5. Tighten the nut by hands then turn 1/2 turn with a wrench.

A
A

UNLESS OTHERWISE SPECIFIED:		NAME	DATE
DIMENSIONS ARE IN INCHES	DRAWN	AD	6/16/17
TOLERANCES:	CHECKED	MNS	6/25/17
FRACTIONS ±	ENG APPR.		
ANGULAR MATCH ±	MFG APPR.		
TWO PLACE DECIMAL ±	G.A.		
THREE PLACE DECIMAL ±	COMMENTS		
INTERPRET GEOMETRIC TOLERANCING PER:			
MATERIAL:			
FINISH:			
NEXT ASSY:	USED ON:		
APPLICATION:		DO NOT SCALE DRAWING	

PROPRIETARY AND CONFIDENTIAL
 THE INFORMATION CONTAINED IN THIS DRAWING IS THE SOLE PROPERTY OF HANNA INSTRUMENTS. ANY REPRODUCTION IN PART OR AS A WHOLE WITHOUT THE WRITTEN PERMISSION OF HANNA INSTRUMENTS IS PROHIBITED.

Water Analytics	
In-line mounting of 585-series sensor	
SIZE: B	DWG. NO.: N106-81
SCALE: 1:4	WEIGHT: 2
SHEET 1 OF 1	